

Entry-Master[®] ***Option-X***

Software Manual



A Publication Provided By



**3106 Lord Baltimore Drive, Suite 100
Baltimore, Maryland 21244
Phone (410) 594-1805
Fax (410) 594-1808**

Table of Contents

1.	Chapter 1 Option-X Software Installation Procedures.....	3
2.	Chapter 2 Hardware Set Up.....	7
3.	Chapter 3 Using the Entry-Master Option-X Software	9
A.	Open and Log In to Software	9
	Main Screen Icons.....	11
B.	Set Date and Time of Hardware With Computer	12
C.	Add, Change, Delete, System Users	13
	Finding, Sorting, Adding, Changing and Deleting Records Icons .	14
	Assigning System User Rights	15
D.	Add, Change, Delete Card Holders	18
	Add A Card Holder.....	18
	Edit or Delete a Card Holder.....	19
E.	Time Zone Definitions.....	20
	Time Zone 1.....	21
	Time Zone 2, Time Zone 3.....	21
	Change a Time Zone	22
	Delete a Time Zone.....	23
F.	Holiday Definitions	23
G.	Access Levels	25
H.	Controller Definitions	26
	View and Edit Controllers.....	27
	Dial Up Controller	28
	Facility Code.....	29
	Adding a Second Controller.....	30
	Two Controllers Communicating to the Same Computer	31
	Copying Time Zones From One Controller to Another Controller	31
	Device Definitions	31
	Reader Device.....	32
	Relay Device.....	33
	Request to Exit or Door Contact Device.....	34
	Door Reporting Incorrectly (Locked When Should be Open).....	35
	Schedule Door to Automatically Unlock.....	36
I.	Load Board.....	37
J.	Device Control (Manually Unlock a Door).....	39
K.	Open Activity Monitor	40
L.	Printing Reports.....	41
A.	Appendix A. Using iButton Tokens.....	44

This Page is Intentionally Left Blank.

Chapter 1 Option-X Software Installation Procedures

1. Using your mouse, left-click on the Start Button beneath your desktop. From the menu list that appears, left-click on Run.
2. Browse to your CD drive, you should see the following executable file in the window.

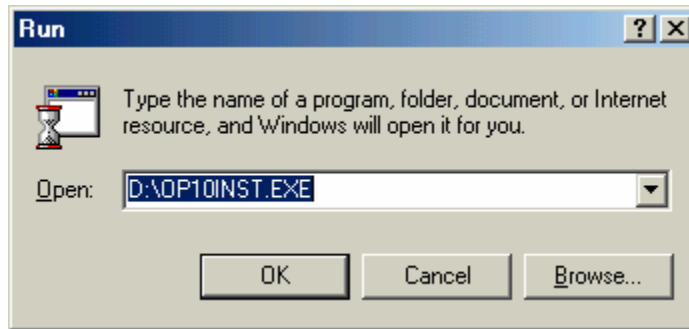

3. Using your mouse, left-click on the Ok button or simply press the Enter key on your keyboard. The following screen will appear:

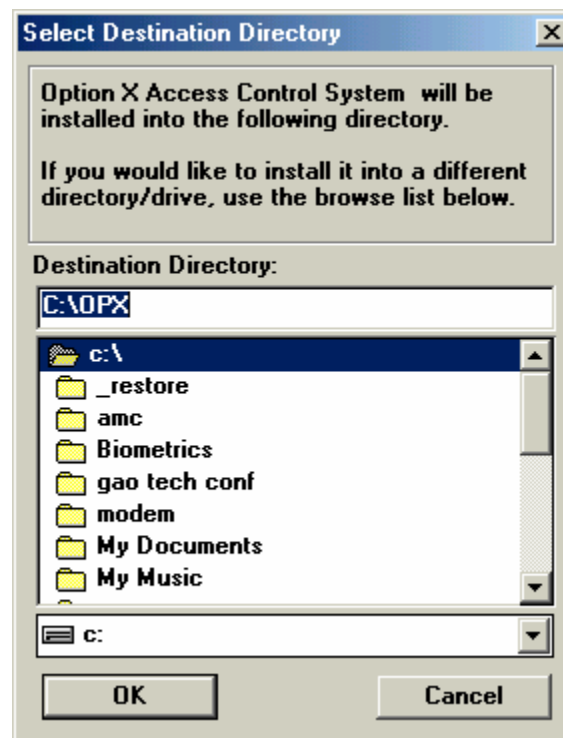

4. It is recommended that you use the specified destination directory. Using your mouse, place the cursor on the OK button or press the Enter key to install the system in the specified directory shown above.

5. The next screen appears. Press the Enter button on your keyboard or using your mouse left-click on the OK button to accept the directory selected for the system database files. The system will begin installing the files to the selected directory.

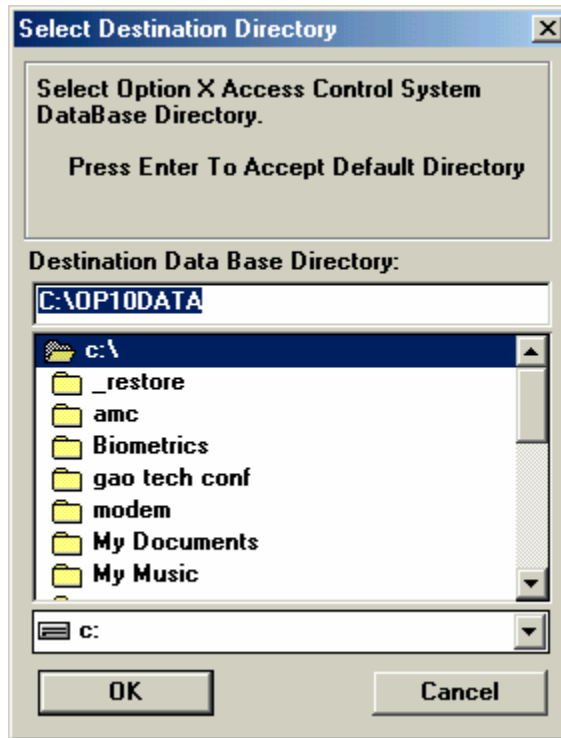

A progress bar will display as the files are copied onto your hard drive as shown in the following screen:

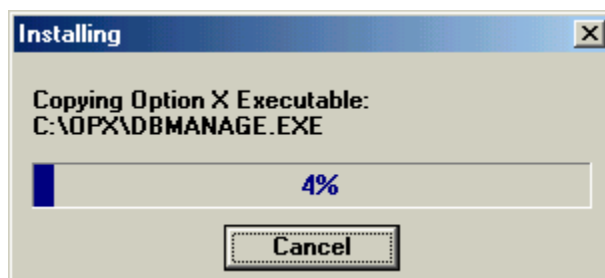

6. Once the system has copied all files into the identified directories you will be prompted to add an icon to start the system on your desktop. Using your mouse click on the Yes button or press the Enter key.

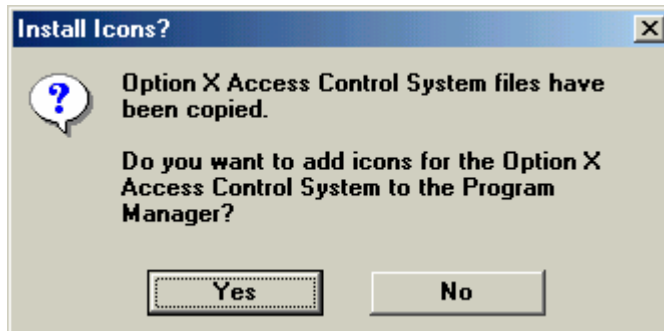

7. You will then be prompted to select the Program Manager group under which to place the Icon. It is best to keep the default option. Press the Enter Key or using your mouse, click on the OK button.



8. The following screen will appear. Using your mouse right-click on the Icon labeled Option-X Access Control as shown in the screen shot below:

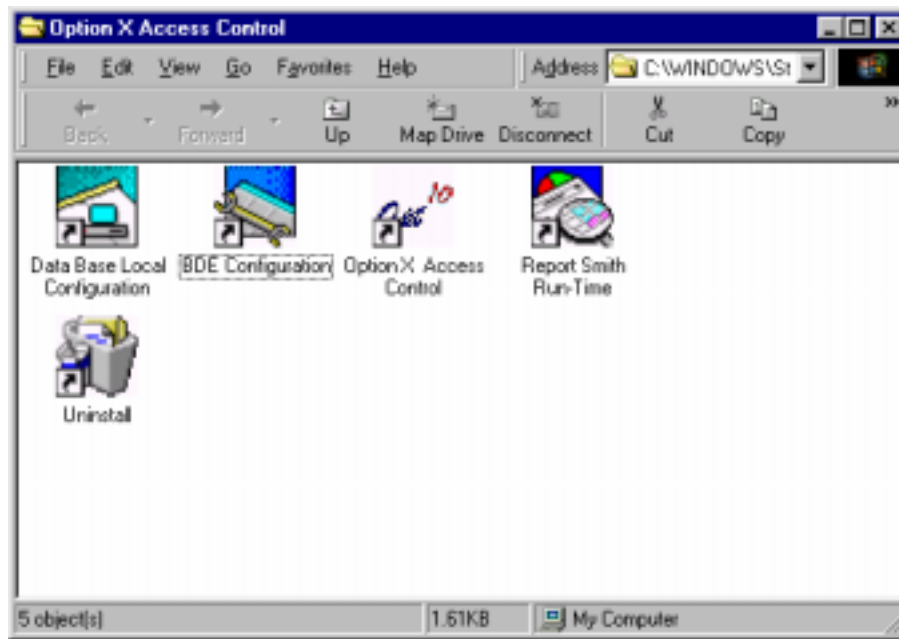

9. When you right-click on the Option-X Access Control icon a menu will appear, select Send To, and Desktop to create a shortcut to install an Icon on your desktop as shown on the sample screen short that follows.



10. Installation is now complete you may close the Option-X Access Control Window. Use your mouse to click on the X in the upper right hand corner of the window.

Chapter 2 Hardware Setup for the Option-2 System

1. First, open your **Entry-Master** Option-2 Enclosure. You will see the following:
 - The Option-2 Board
 - The *Option-X Software* CD
 - A Set of Enclosure Keys
 - A 9-Pin RS232 Communication Cable.

If your desktop or laptop does not have a 9-pin RS232 port you will need to purchase a USB to RS232 converter cable. This can be purchased at Radio Shack, Office Depot or Staples.

2. Connect the power cable to the blue screw connector, located at P1 on the circuit board inside your Option-2 enclosure, to a 12 VAC transformer. Connect the transformer into a standard 110V outlet. You will see a green light blink on and off.



The Option-2 enclosure, circuit board, and communications cable

3. Connect the RS232 cable to your 9-pin RS232 port on your desktop or laptop. If you do not have a 9-pin RS232 port, use the adapter described above. Connect the RS232 cable attached to the Entry-Master Option-2 Enclosure to the 9-pin RS232 end of your converter cable. Connect the USB end of the converter cable to a USB port on your laptop or desktop.
4. Once you have connected your Entry-Master Option-2 Enclosure to your desktop or laptop you are ready to configure your software. Refer to the Option-2 board diagram below for connections:

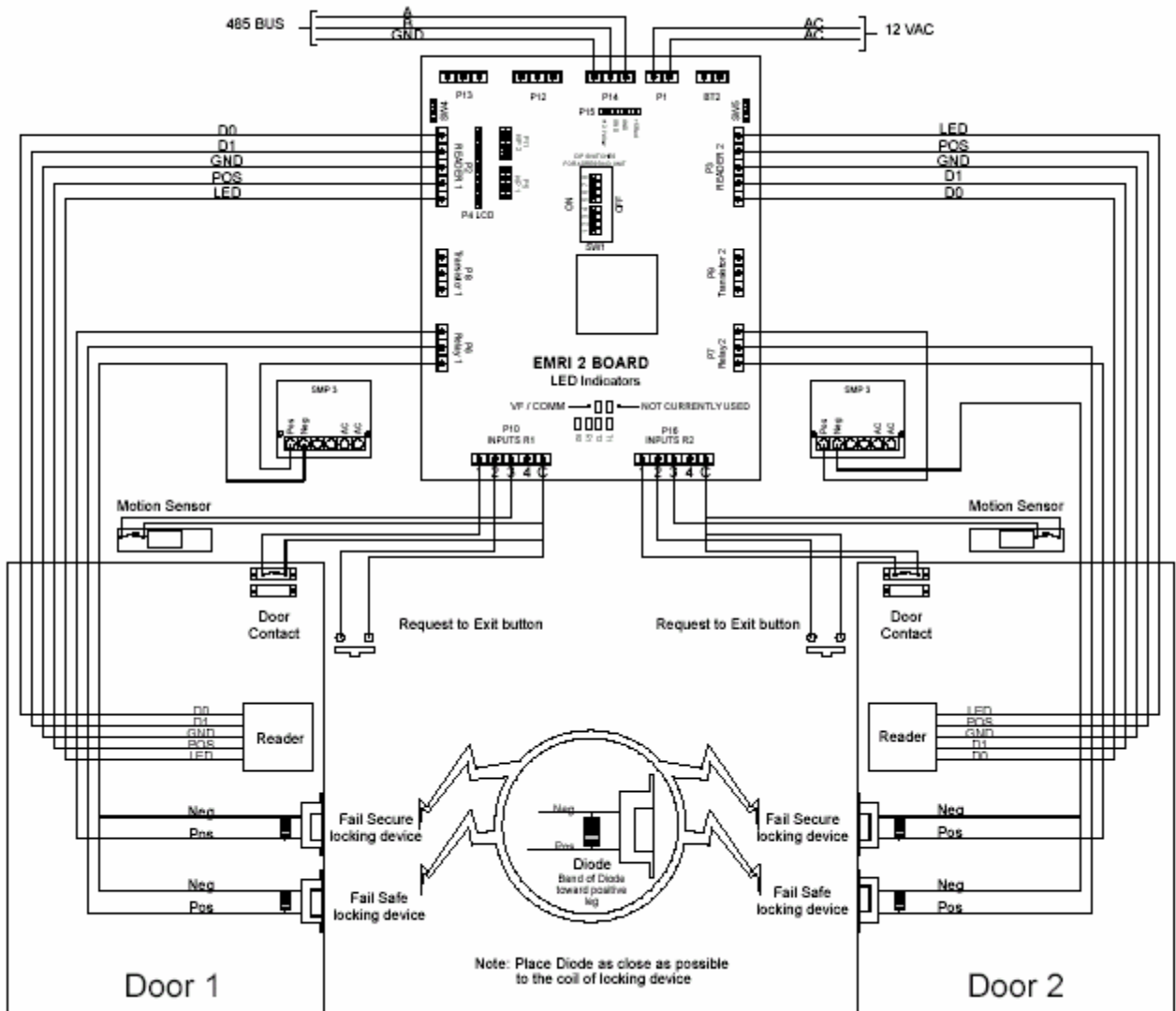

Connecting Readers and Lock Mechanisms to the Option-2 board

Note: More detailed information on Option-2 hardware can be found in the *Entry-Master Option-2 Hardware Installation Guide*.

Chapter 3 Using the *Entry-Master* Option-X Software

A. Open and Log in to Software

1. Connect the power cable to a power outlet and connect the RS232 cable to your 9-pin communication port on your computer or laptop. See **Chapter 2 Hardware Set Up For the Option-2 System, items 2 and 3** for more detailed instructions.
2. To open the software, using your mouse double click on the *Option-X* Access Control icon on your desktop or click on Start, then Programs, next Option-X Access Control, and finally click on *Option-X* Access Control. The following screens will appear:

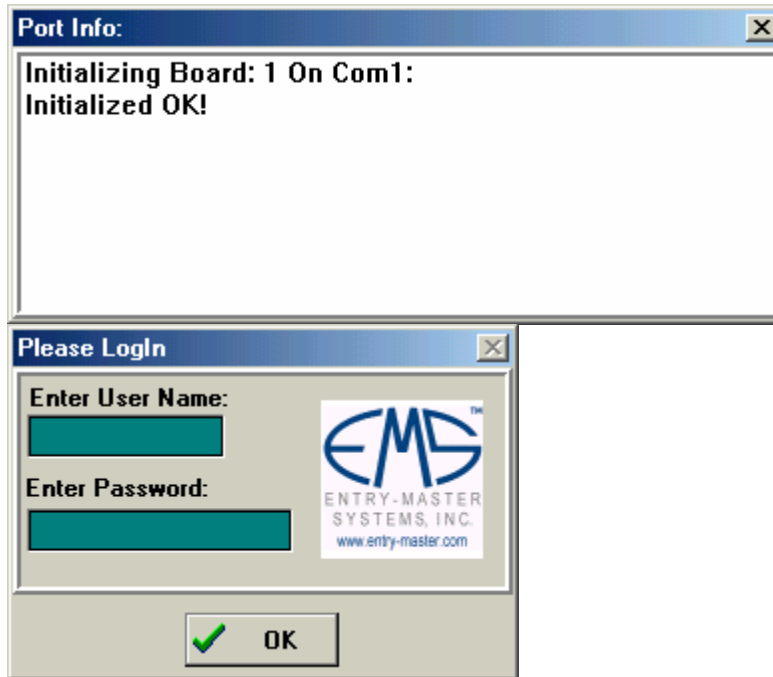

3. The top screen, **Initialized OK!** message indicates your laptop or desktop is communicating successfully with the Option-2 circuit board.

If the **Please Login** screen does not appear immediately, then you more than likely are not communicating with the Option-2 board. The default setting is for the Option-2 board to communicate on **COM1**; if your computer's **COM1** port is not available, then see **Section H. Controller Definitions** on page 28 to change the **Port Number** to the appropriate value.

The **Port Number** corresponds to the **COM** port to which the Option-2 is attached (i.e. **COM6** would require changing the **Port Number** to a number '6').

- Now using your mouse, click on the window under Enter User Name: and type in **SUPERVISOR** into the **User Name** Field.



- Next using your mouse, click on the **Enter Password:** window and type in the password **USER**. The password is not case sensitive.

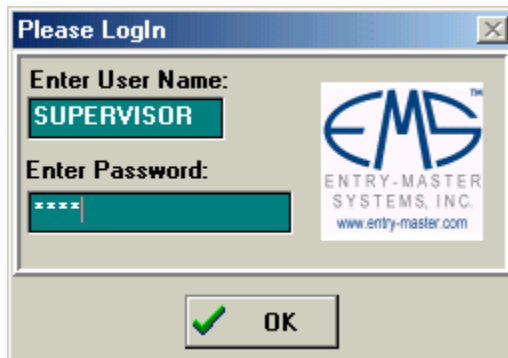

- Using your mouse, left-click the OK button to open the software. The following screen will appear:

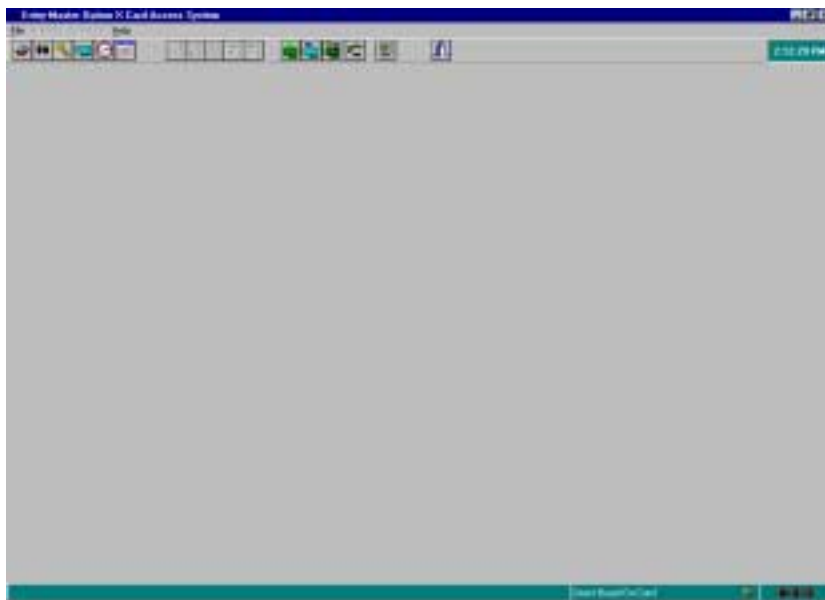

- The screen shot below identifies the **Main Screen Icons** across the top of the opening page. Position your cursor on any icon and the functional name of the icon as printed below will display.

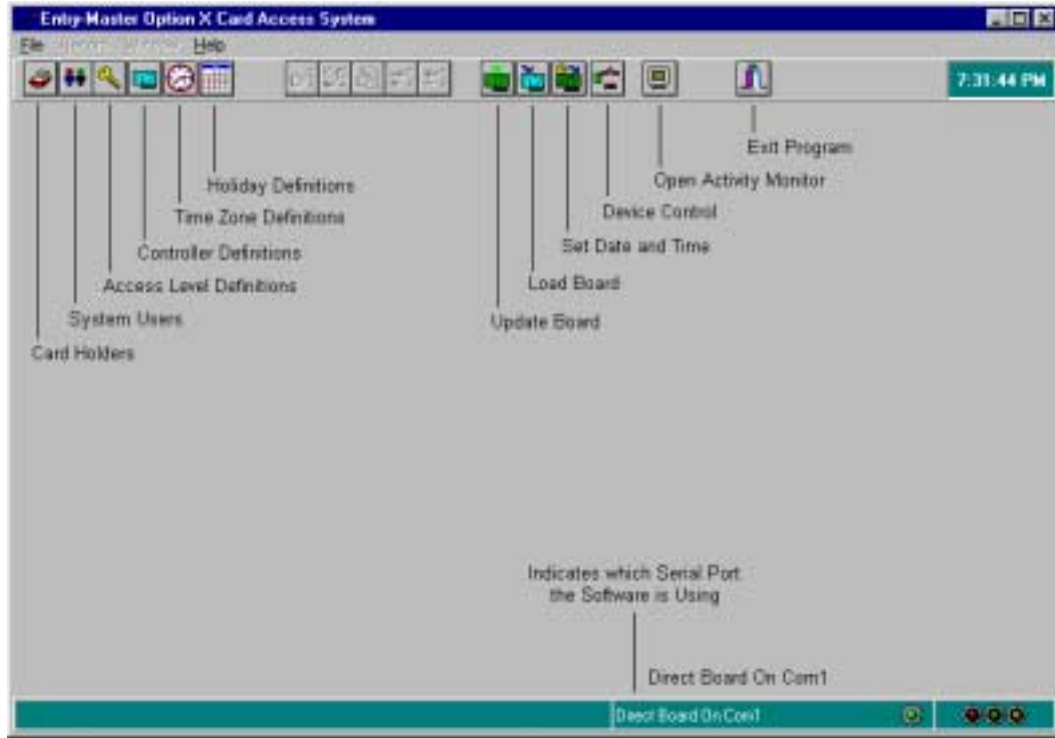

- You may also use the drop-down menu, under the **File** option:

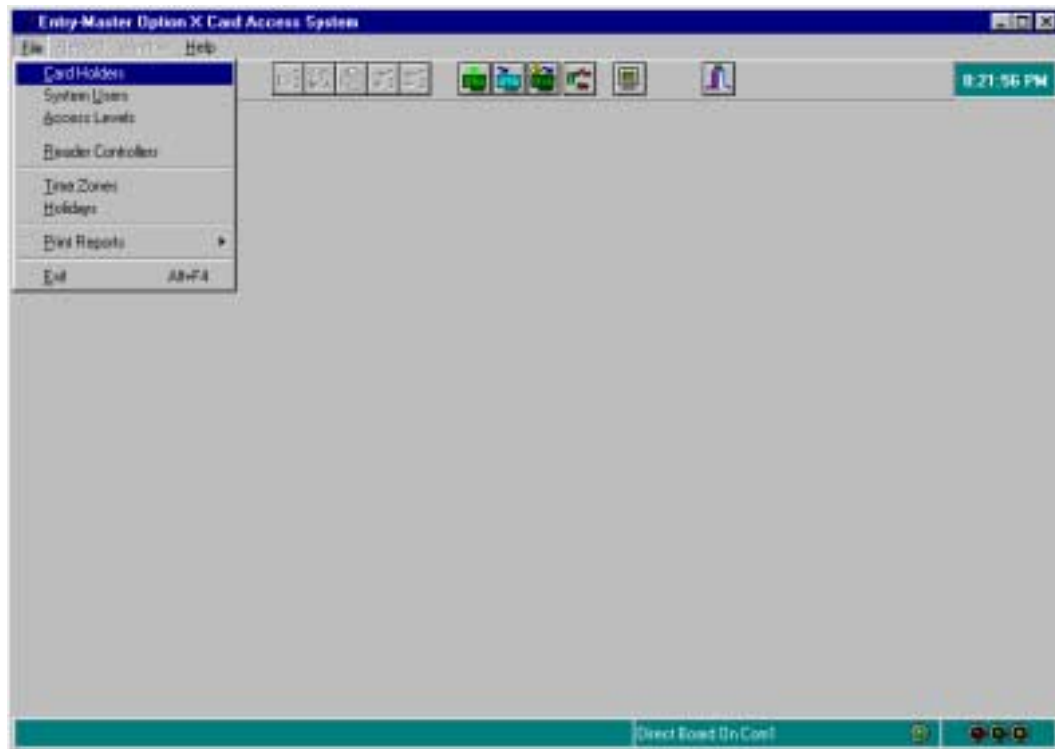

B. Set Date and Time of Hardware with the Computer

1. The next step is to set the date and time of the Entry-Master Option-X hardware.
2. Using your mouse, right-click on the Set Date and Time icon and a new window opens on top of the opening page of the software, as shown below.

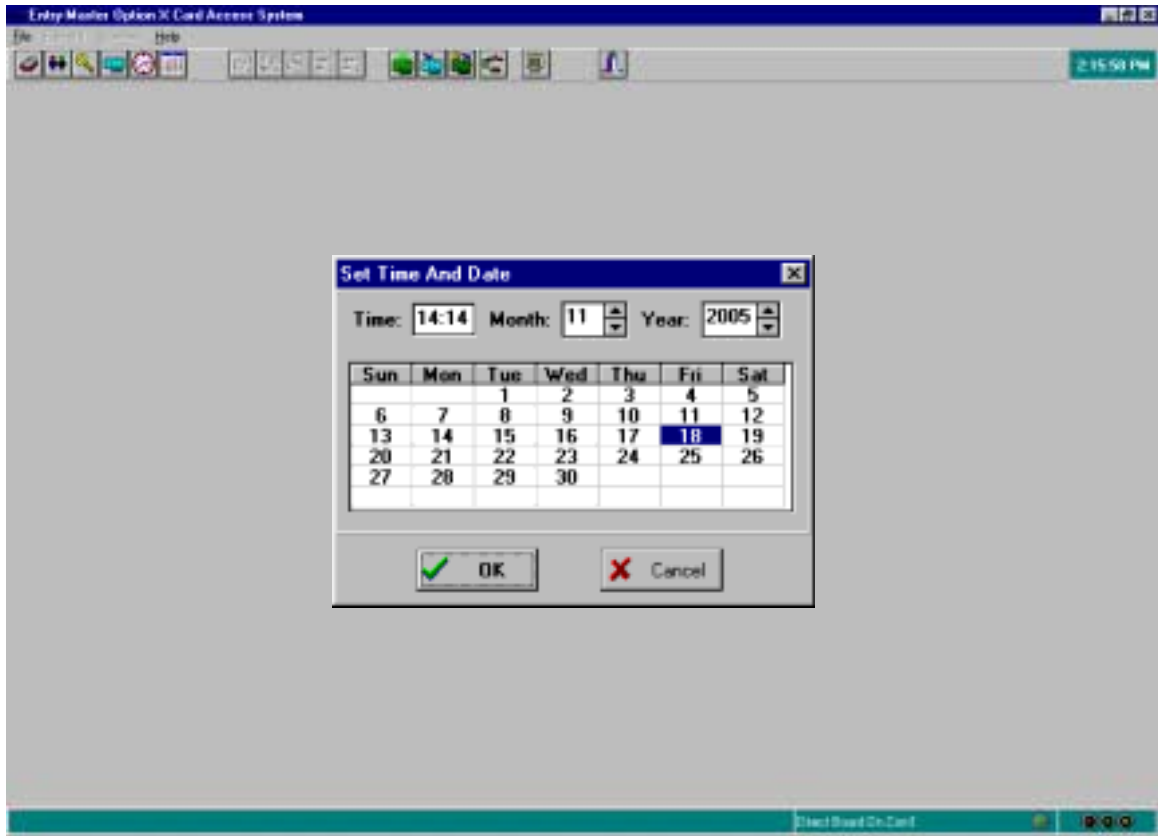

3. Using your mouse, click in the Time window, enter the current time using 24 hour military time. For example: 9 am would be entered as 09:00, while 1:30 PM would be entered as 13:30. In the example above, 14:14, represents 2:14 PM.
4. Next, click in the Month window and enter the number representing the current month. In the example above, 11 represents the month of November.
5. Verify in the calendar below the Time, Month, and Year windows that the correct date is highlighted. In the example above, Friday the 18th of November 2005 is highlighted.

6. Verify the correct year is displayed in the Year window. Then using your mouse, click on OK or press the enter key on your keyboard. The following window appears:

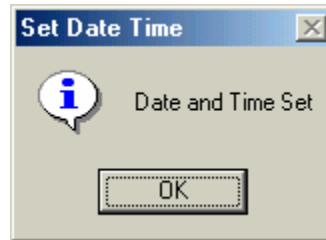

Press the enter key or using your mouse, click on the OK button.

C. Add, Change (Edit), Delete System Users

1. A system user is an individual who has permission to open the Entry-Master *Option-X* software and to perform system functions. The **SUPERVISOR** is a default user for the first time use of the software. You may leave this **User Name** with its default password or you may change the **User Name** and/or the **Password**.
2. To change the default System User, use your mouse to click on the System Users Icon, or click on the word File at the top of the window and from the drop down menu that appears select System Users. The following window is displayed:

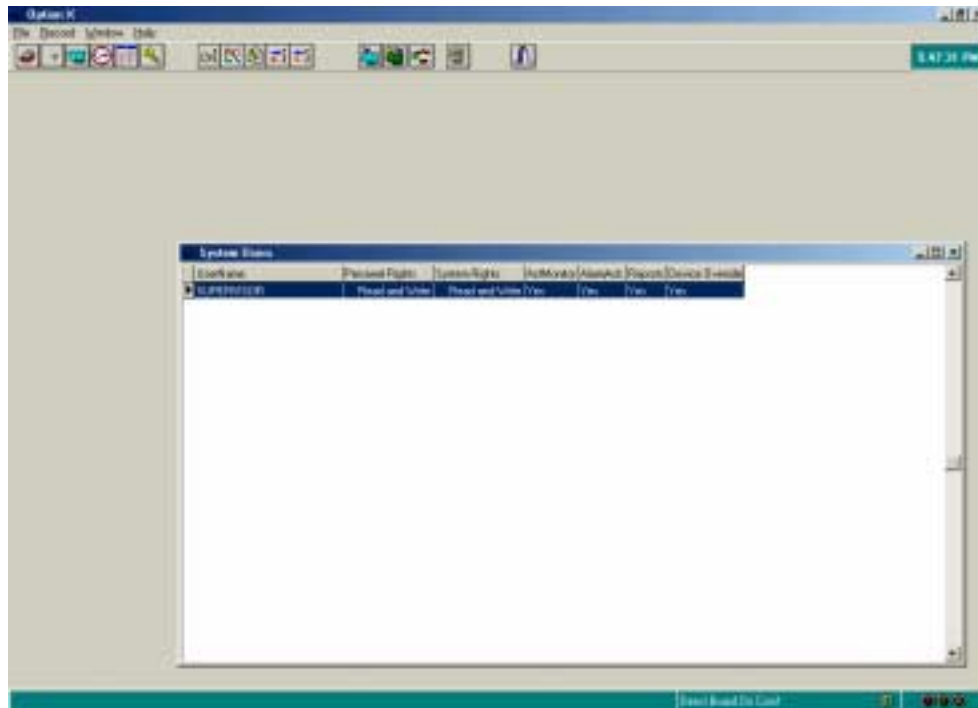

3. **Icons for Finding, Sorting, Changing, Adding and Deleting** records are now displayed. The screen shot below identifies each icon. Position your cursor on any icon and the functional name of the icon as printed below will display.

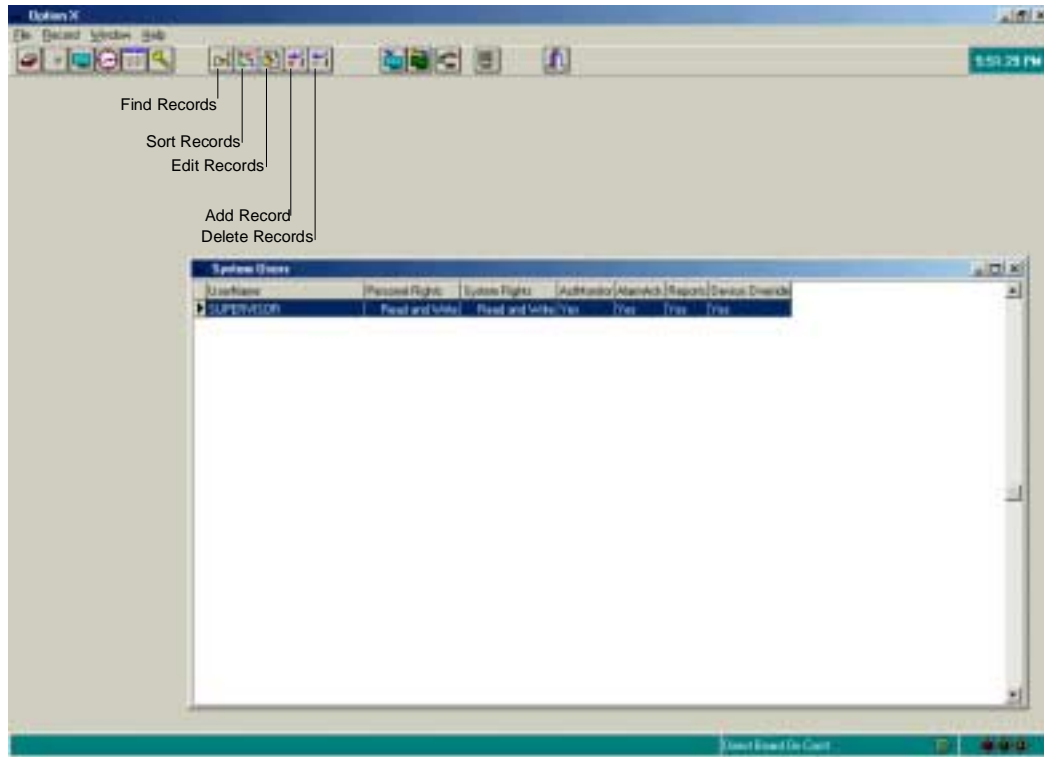

4. To change the **UserName SUPERVISOR** to a different name, highlight the entry as shown in the screen display above and using your mouse, double click on the highlighted entry. Or place your cursor on the Edit Record button. A window opens as shown in the screen shot on the following page:

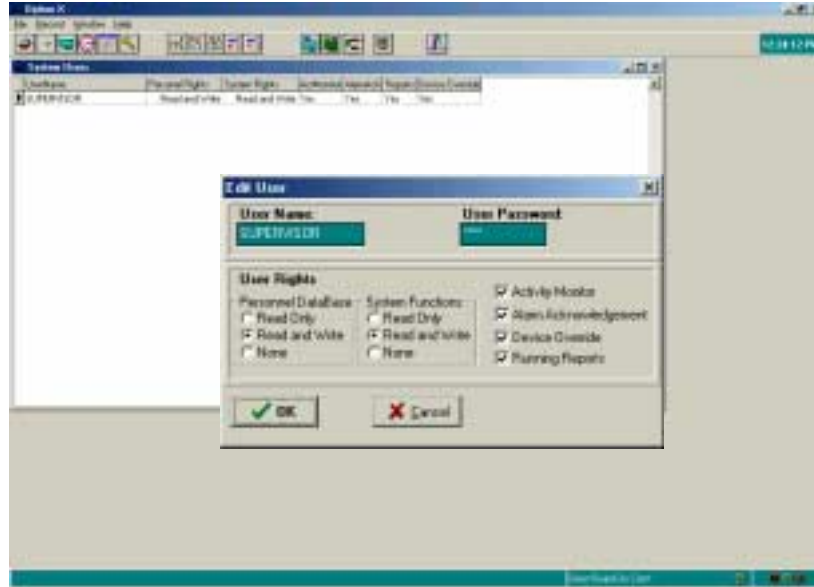

- Place your cursor in the **User Name** window, highlight the name in the window, **SUPERVISOR**, and type over with the new user name you wish to use. Do the same for the **User Password**. For example:

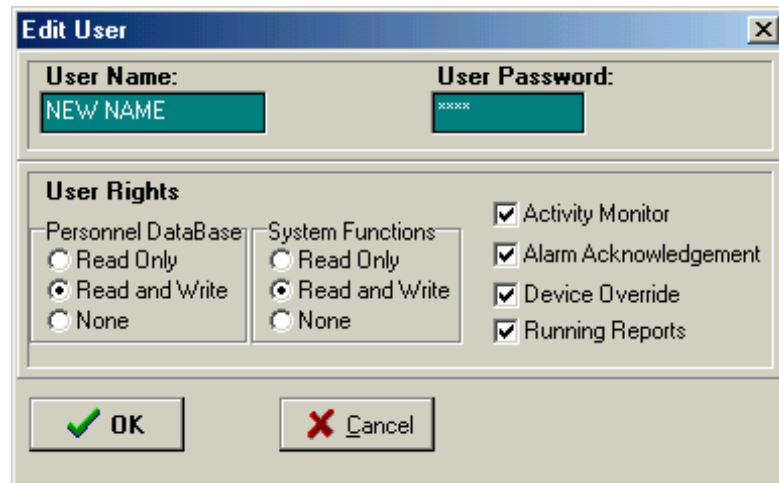

- Notice the section titled **User Rights**. These are the items the system user can read or modify depending on the capability selected.

Personnel Database – Refers to the ability to add, change or delete Card holders.

System Functions – Refers to the ability to add, change or delete: Controller Definitions, Time Zone Definitions, Holiday Definitions, Access Definitions, Add a New Controller Board, Set the System Date and Time, and Device Control (control individual door locks & relays).

- **Read Only** – when selected allows the system user to only Read Information contained in each software menu selection.
- **Read and Write** – when selected allows the system user to both Read and change information contained in each software menu selection.
- **None** – when selected the system user is unable to access or modify related software menu selections.

Activity Monitor – when checked allows the system user to open the real time activity monitor to see transactions as they occur in real-time.

Alarm Acknowledgement – when checked allows the system user to acknowledge alarms such as a door left open, unauthorized access attempt, etc. **Alarm acknowledgement is currently not implemented into the Option-X software.**

Device Override – when checked allows the system user to override the system to unlock a door in real time.

Running Reports - when checked allows the system user to run either of the two reports in the *Option-X Software*, **Personnel** or **Transaction History** reports.

If the user attempts to access a software menu item he is has not been given permission to access the following window will pop up:

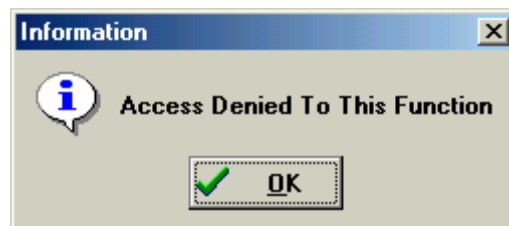

7. To add a system user, open the System Users window by using your mouse to click on the **System Users** icon, or select **File** and **System Users** from the pull down menu that appears. Then using your mouse click on the **Add A Record Button**. The following window pops up:

Edit User

User Name:

User Password:

User Rights

Personnel DataBase

Read Only

Read and Write

None

System Functions

Read Only

Read and Write

None

Activity Monitor

Alarm Acknowledgement

Device Override

Running Reports

Place your cursor in the **User Name** field. Enter the new **User Name** in the field. Do the same for the **User Password**. Then select the **User Rights** the new user will have. Using your mouse left-click on the **OK** button or simply press the **<Enter>** key on your keyboard to enter the new user into the system software.

- To Delete a System User, open the System Users window by using your mouse to click on the System Users icon, or select File and System Users from the pull down menu that appears. Highlight the record to be deleted. Then using your mouse click on the **Delete A Record Button**. The following window pops up:

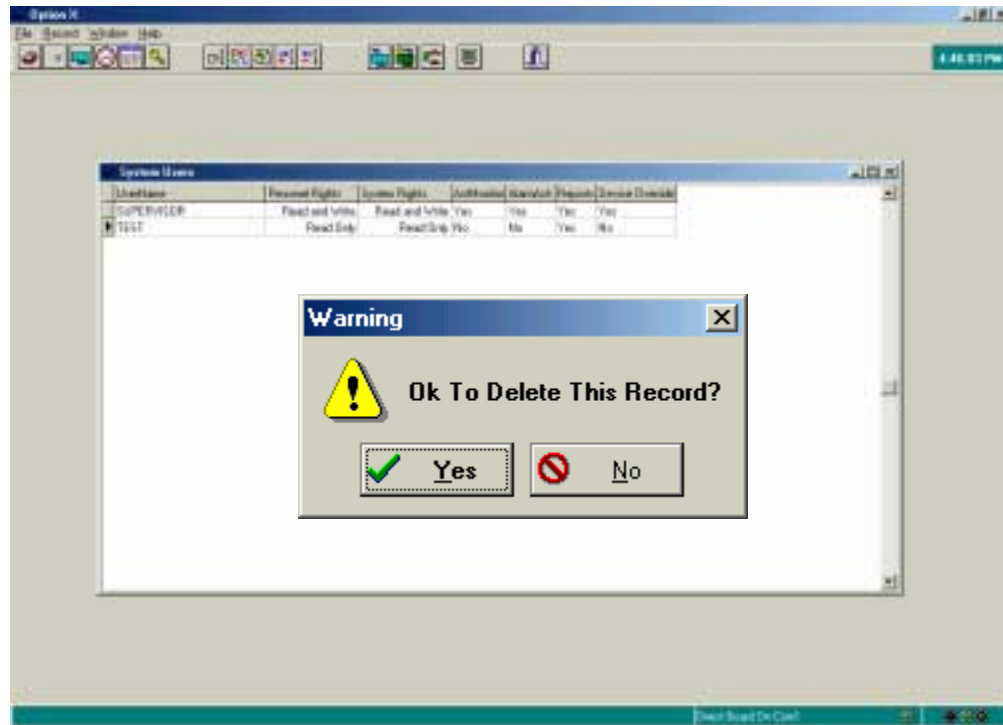

Note: The highlighted record loses the highlight and instead has an arrow pointing to it.

9. Confirm the record you wish to delete by using your mouse to click on the **OK** button or press the **<Enter>** key on your keyboard.
10. To exit the System Users Window, click on the 'x' in the right hand corner of the window directly opposite from the blue bar titled **System Users**.

D. Add, Change (Edit), Delete Card Holders

1. A card Holder is an individual who has permission to enter selected doors using a company provided proximity card. Using your mouse click on the Card Holders Icon, or click on File and select Card Holders from the pull down menu. The following window will pop up:

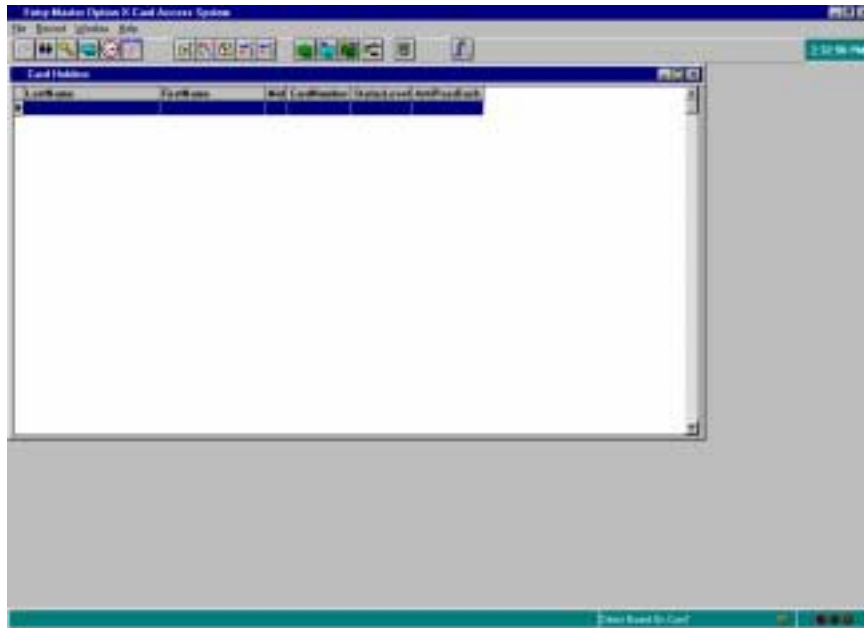

2. To add a new card holder, double click on the **Add Record button**. The window on the following page will pop up.
3. Using your mouse click in the **Last Name** field. Enter the employee's last name. Follow the same procedure for **First Name** and **Initial**.
4. For **Card Number**, enter the number on the card assigned to the employee. The card number will be from **one** to **six** digits in length.

The screenshot shows a dialog box titled "Edit Card Holder". It contains the following fields and options:

- Last Name : [Text Field]
- First Name : [Text Field]
- Initial : [Text Field]
- Card Number : [Text Field] iButton 00000
- Access Level : [Text Field] 1
- AntiPassback : [Radio Buttons]
 - In
 - Out
 - Neutral/Forgive
 - Master

At the bottom right, there are two buttons: "OK" (with a green checkmark icon) and "Cancel" (with a red X icon).

5. If you are using an Option-4 system, type the last five letters or numbers that appear on the **iButton** token. See **Appendix A** for more detailed information on **iButton** tokens and their use with Option-4.
6. The **Access Level** defaults to **1**, this refers to the doors the employee has permission to enter by time of day. An **Access Level** of **1** provides access to all doors, every day of the week, 24 hours a day. To create new access levels see **Section G, Access Level Definitions**.
7. Click on the appropriate *Radio Button* to indicate the Card holder's **Anti-Passback** status. The default is **Neutral**, and it is highly recommended that all cards be added with **Neutral** status.

Anti-Passback is normally used in parking, and will be discussed at length in **Appendix B**.
8. Using your mouse, click on the OK button. Another **Edit Card Holder** window will appear. When all employees have been entered and assigned a card number, click on the **Cancel Button** and then click on the 'x' in the right hand corner on the blue bar of the **Edit Card Holder** window to exit this function.
9. To change parameters for a **Card Holder**, highlight the Card Holders name and type over the information you wish to change.
10. To delete a **Card Holder**, highlight the card holders name and click on the Delete Record Icon, (**See Page 14**).
11. Click on the 'x' in the right hand corner on the blue bar of the **Edit Card Holder** window to exit this function.

E. Time Zone Definitions

1. Time Zone Definitions enable you to efficiently define the shifts (days and time of day) employees have access to doors. To view and/or change preconfigured time zones left-click on the **Time Zone Definitions** icon or left-click on **File** and from the menu select **Time Zones**. The following screen will display:

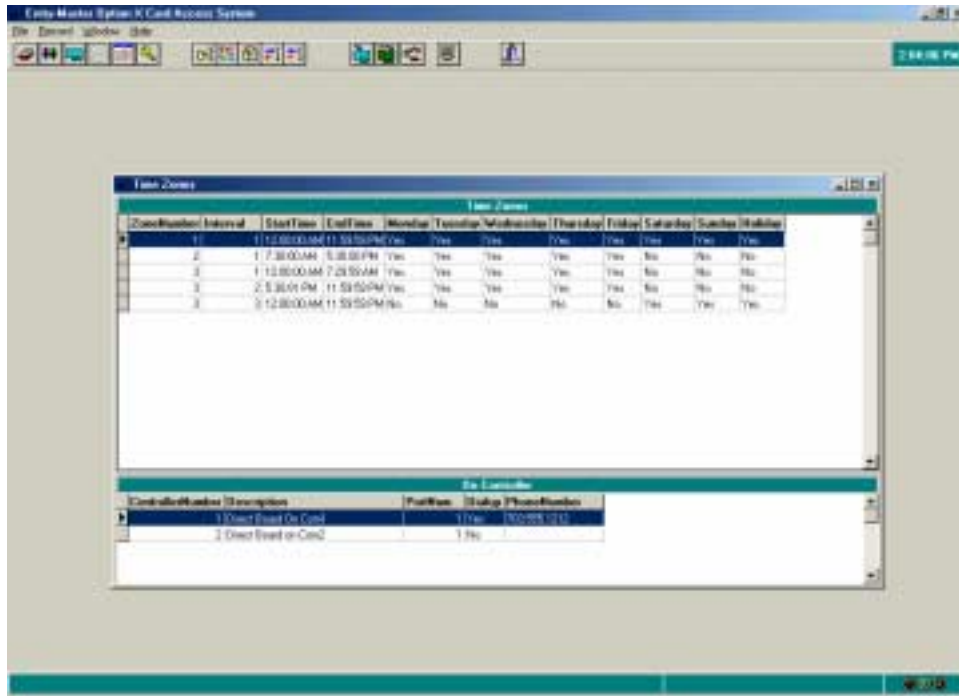

2. The Option-X Card Access System software contains pre-configured time zones, 1,2, and 3. To view and/or change pre-configured time zones double click on a specific time zone. For example **Time Zone 1**, the following screen will display.

Time Zone
✕

On Controller	Number	Interval
Direct Board On Com1	1	1

StartTime	12:00:00 AM	EndTime	11:59:59 PM
-----------	-------------	---------	-------------

<input checked="" type="checkbox"/> Monday	<input checked="" type="checkbox"/> Tuesday	<input checked="" type="checkbox"/> Wednesday	<input checked="" type="checkbox"/> Thursday
<input checked="" type="checkbox"/> Friday	<input checked="" type="checkbox"/> Saturday	<input checked="" type="checkbox"/> Sunday	<input checked="" type="checkbox"/> Holiday

✔ OK	✕ Cancel
--	--

3. **Time Zone 1** has only one interval (one time shift). It begins Monday, starting at midnight (12:00:00 AM) and runs continuously until 11:59:59 PM, picking up again at midnight on Tuesday, running continuously until 11:59:59 PM Tuesday, picking up again at midnight Wednesday and so on. **Time Zone 1** provides for 24 hour access, every day of the week and on holidays. **See Section G to define Holidays.**
4. **Time Zone 2** also has only one interval (one time shift) as defined in the screen shot below. **Time Zone 2** begins at 7:30 AM and ends at 5:30 PM and is valid on week days only: Monday through Friday.

The screenshot shows a dialog box titled "Time Zone" with a close button (X) in the top right corner. The dialog is divided into several sections:

- On Controller:** A text field containing "Direct Board On Com1".
- Number:** A numeric input field containing the value "2".
- Interval:** A numeric input field containing the value "1".
- StartTime:** A time selection field set to "7:30:00 AM".
- EndTime:** A time selection field set to "5:30:00 PM".
- Days:** A grid of checkboxes for days of the week:
 - Monday:
 - Tuesday:
 - Wednesday:
 - Thursday:
 - Friday:
 - Saturday:
 - Sunday:
 - Holiday:
- Buttons:** At the bottom, there are two buttons: "OK" with a green checkmark icon and "Cancel" with a red X icon.

An employee assigned an access level of **Time Zone 2** would not be allowed to enter the defined door on Saturday, Sunday, or Holidays or on weekdays before 7:30 am or after 5:30 PM.

5. **Time Zone 3** has three different intervals (time segments). The primary purpose of this time zone is to define alarm events. For example, the front door may be propped open during business hours but during off hours the door should not be propped open and instead an alarm should occur to signal this event.

The screenshot shows a dialog box titled "Time Zone" with a close button (X) in the top right corner. The dialog is divided into several sections:

- On Controller:** A text field containing "Direct Board On Com1".
- Number:** A numeric input field containing the value "3".
- Interval:** A numeric input field containing the value "1".
- StartTime:** A time selection field set to "12:00:00 AM".
- EndTime:** A time selection field set to "7:29:59 AM".
- Days:** A grid of checkboxes for days of the week:
 - Monday:
 - Tuesday:
 - Wednesday:
 - Thursday:
 - Friday:
 - Saturday:
 - Sunday:
 - Holiday:
- Buttons:** At the bottom, there are two buttons: "OK" with a green checkmark icon and "Cancel" with a red X icon.

- To change an existing shift or interval double click on the entry as shown below:

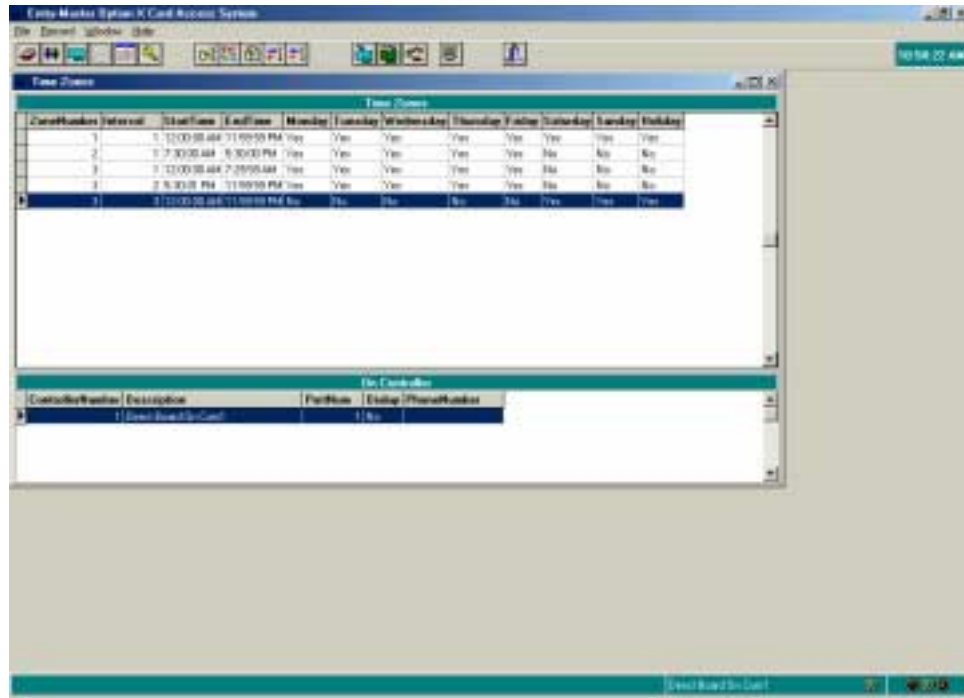

- Move your cursor to the **Start Time**. Using your keyboard enter the new **Start Time**, be sure to include AM or PM as appropriate, move your cursor to the **End Time** and enter the change you wish to make. Identify the days for which this access interval is valid by clicking in the box. Each day would be selected as displayed in the screen below. The original interval included only **Saturdays, Sundays and Holidays**. To add **Friday** simply use your cursor to click on **Friday** as shown in the display below:

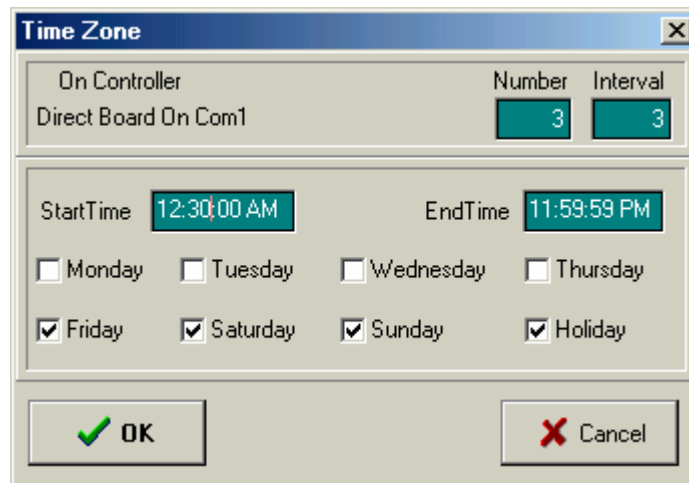

Left-click on the **OK** button to create the new interval and it will be displayed as a line item in the master list of **Time Zones** screen.

8. To delete a Time Zone, highlight the line item you wish to delete by using your mouse to left-click on the line once, then click on the **Delete Record Icon**. (See Page 14)

F. Holiday Definitions

1. Holiday definitions enable you to define specific dates designated as holidays to either enable or deny employee access on those dates.
2. Using your mouse left-click on the **Holiday Definitions Icon** or left-click on **File** and from the drop down menu select **Holidays** and the following screen will display:

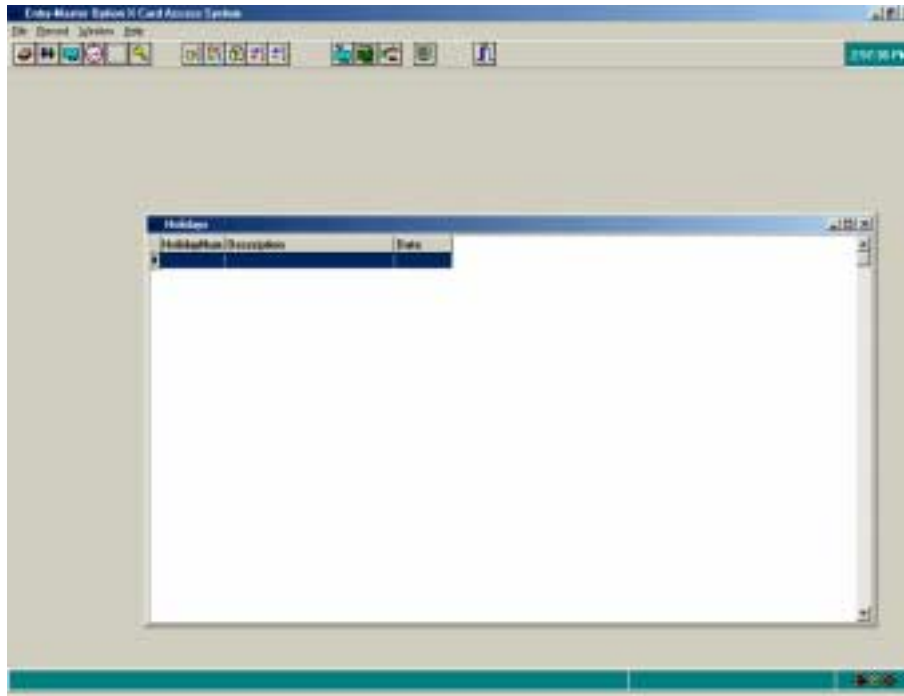

3. To add a holiday, left-click on the **Add Record** icon. The following screen will display:

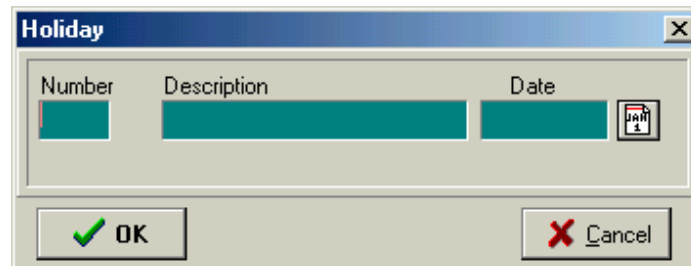
A screenshot of a dialog box titled "Holiday". It has a title bar with a close button. The dialog contains three input fields: "Number", "Description", and "Date". To the right of the "Date" field is a calendar icon. At the bottom of the dialog are two buttons: "OK" with a green checkmark icon and "Cancel" with a red X icon.

4. Enter number 1 in the **Number Field**, then enter the holiday name in the **Description Field**. For example:

Number	Description	Date
1	Labor Day	

5. Left-click on the calendar date and a calendar will display as follows:

September, 2005						
Sun	Mon	Tue	Wed	Thu	Fri	Sat
				1	2	3
4	5	6	7	8	9	10
11	12	13	14	15	16	17
18	19	20	21	22	23	24
25	26	27	28	29	30	

6. To change the month displayed press the up arrow to go back a month, press the down arrow to go forward a month. Select the date then click on the **OK** button. To accept the entries as shown below:

Number	Description	Date
1	Labor Day	9/5/2005

7. Click the **OK** button to enter the holiday into the Holidays screen:

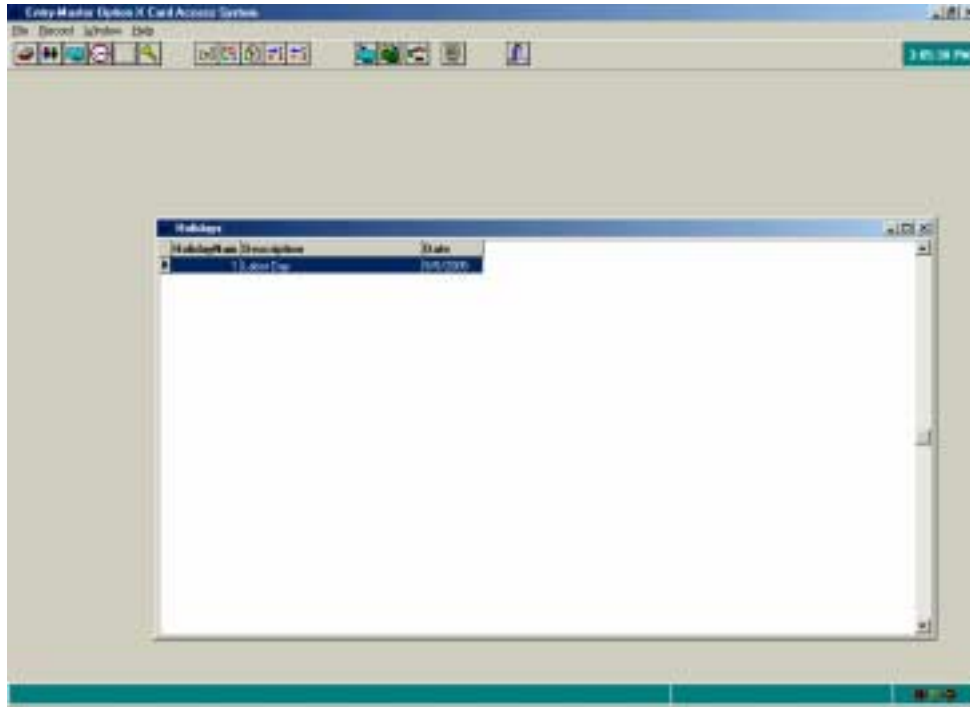

G. Access Level Definitions

1. Access level defines the days of the week and time of day when employees are allowed to enter a specific door. To view and/or change preconfigured access definitions left-click on the **Access Level Definitions** icon or left-click on **File** and from the menu select **Access Levels**. The following screen will display:

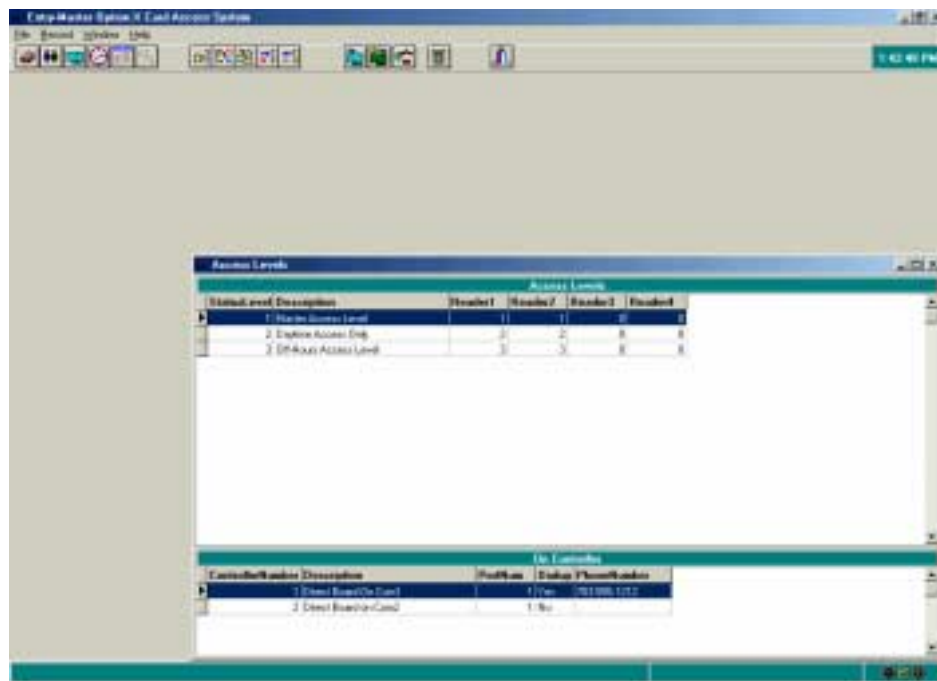

- The Option-X Card Access System software contains three pre-configured access levels that refer back to defined Time Zones.



- In the display above, Readers 1 and 2 are assigned a specific **Zone Number (Time Zone)** of 1. The **Zone Number** defines the days and times an employee has permission to enter through the defined door. Note that Readers 3 and 4 are assigned Zone Number 0. When a second controller is added to the system, Readers 3 and 4 become active and would be assigned a Zone Number. (**See Section H Controller Definitions, Items 11 through 14**).

H. Controller Definitions

- The controller is the circuit board inside your Option-2 Enclosure. The Option-X Access Control Software loaded on your desktop or laptop communicates the information entered to the controller. Using the information entered the controller determines whether a card user has permission to access a door assigned to the Option-2 Access Control System. Prior to entering access information into the software the controller board must be set up to communicate to the software to be able to receive and send information or receive and execute commands. **See Chapter 2 Hardware Set Up.**
- Your controller is already configured and probably does not require any software modification. The most likely field you will change in the Controller Definition is the System Code described in **Item 7** below. Using your mouse, left-click on the Controller Definitions Icon. The following window pops up:

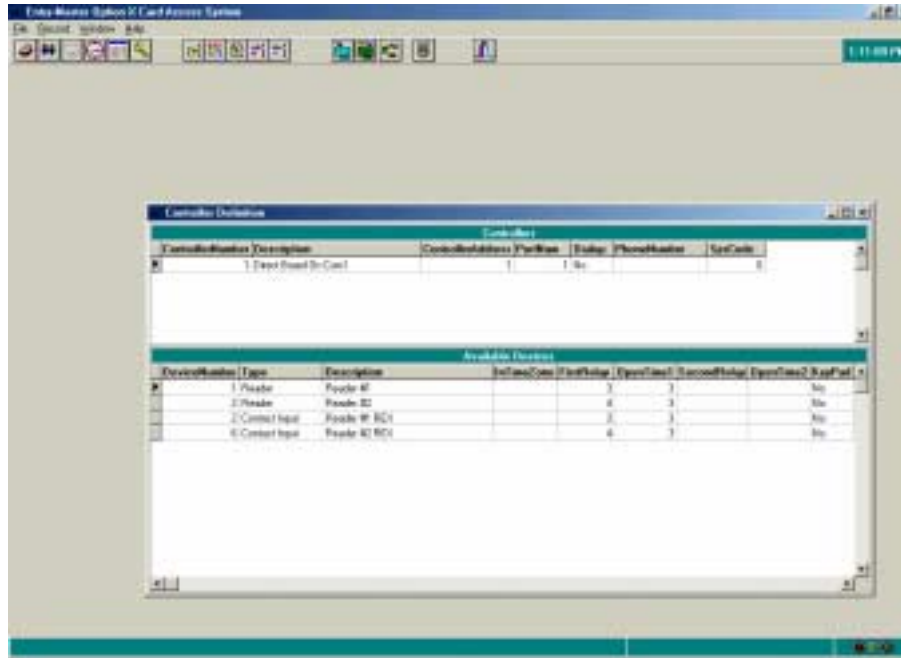

- Notice in the screen shot above, there are two sections. One labeled **Controllers** and the other **Available Devices**. As mentioned in # 1 above, the controller is the circuit board inside your Entry-Master Enclosure. The **Available Devices** is a list of the card readers and information about the lock and other devices associated with the door(s) that the controller is managing. The information contained in the window can be entered, changed, or deleted by highlighting and double clicking on the selected controller or device.
- To view the Controller definition information, using your mouse, double click on the highlighted Controller.

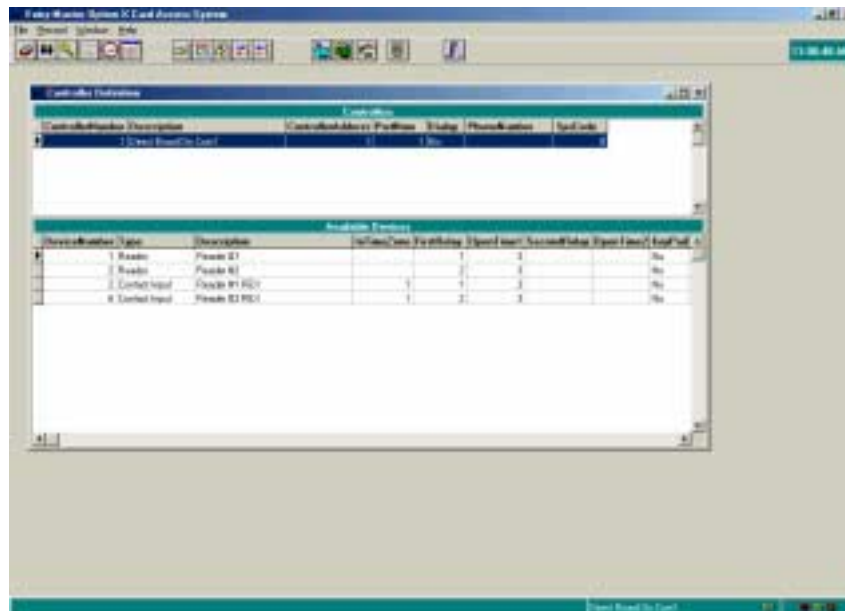

- The next window pops up displaying the current definitions as shown below.

The screenshot shows a dialog box titled "Edit Controller". It has a close button (X) in the top right corner. The dialog is divided into several sections:

- Number:** A text box containing the value "1".
- Description:** A text box containing the value "Direct Board On Com1".
- Address:** A text box containing the value "1".
- Port Number:** A text box containing the value "1".
- Sys Code:** A text box containing the value "0".
- Dialup Controller:** A checkbox that is currently unchecked.
- CallBack Wait Time:** A text box containing the value "1" followed by the text "Seconds".
- PhoneNumber:** An empty text box.
- TZ Copy From Board #:** An empty text box.
- Access Copy From Board #:** An empty text box.

At the bottom of the dialog, there are two buttons: "OK" with a green checkmark icon and "Cancel" with a red X icon.

- Warning: Do not change the values for the following parameters: Number, Address and Port Number, unless directed to do so by your dealer.**
- These values refer to specific functions on the circuit board installed in your enclosure (your Option-X Access Control hardware panel). To do so will affect the Option-X Access Control software ability to communicate with the Option-X Access Control hardware. The exception would be when adding a second controller, see **Section 10** below.
- To communicate with an Option-X Access Control hardware panel installed in a remote location, you will need to connect the panel to a modem and connect the modem to an analog telephone line. In this instance, using your cursor left-click to place a check mark in the square next to **Dialup Controller**. Enter the number of seconds the software is to wait to retry calling the connection. Enter the phone number of the telephone line connected to the modem. As an example see the screen below:

9. The **Sys Code Field** refers to a system code, or **Facility Code** that has been assigned to the cards provided to employees for access. A value of 0 indicates that the facility code will not be used, i.e. be ignored. To require the Option-X Card Access System to read the system code, **Facility Code**, enter the code assigned to the cards in the **Sys Code Field**.
10. The facility code is usually printed on the label on the outside of the box in which your cards were shipped. It is sometimes abbreviated as FC or F/C and the facility code is typically a number between 1 and 255. Contact your dealer if you are unable to identify the facility code.
11. To add a second controller left-click on the **Add Record** icon (**Refer to Page 14**). The following screen will display:

12. Place the cursor in the **Number Field**, left-click and enter 2. Place the cursor in the **Description Field**, left-click and enter a name to associate with the second controller. For example:

13. When using two controllers, each controller must have a unique **Address**. When using two controllers cabled directly to the same computer, the **Port Number** for each controller must be unique and coincide with the Windows port number (i.e. com 1, com 2, etc.)

When using two controllers, each communicating to the same laptop through different phone lines, the addresses and phone numbers will be different but the Port Numbers will be the same. For example:

14. Each controller may have its own time zone and access levels. **Note: All Controllers Share The Same Card Database.** If your access levels and time zones are exactly the same then left-click on the **TZ Copy From Board #** field and left-click on the **Access Copy From Board #** field enter 1 in both fields. This tells the software to copy the time zones and access levels created for Controller 1 as shown below:

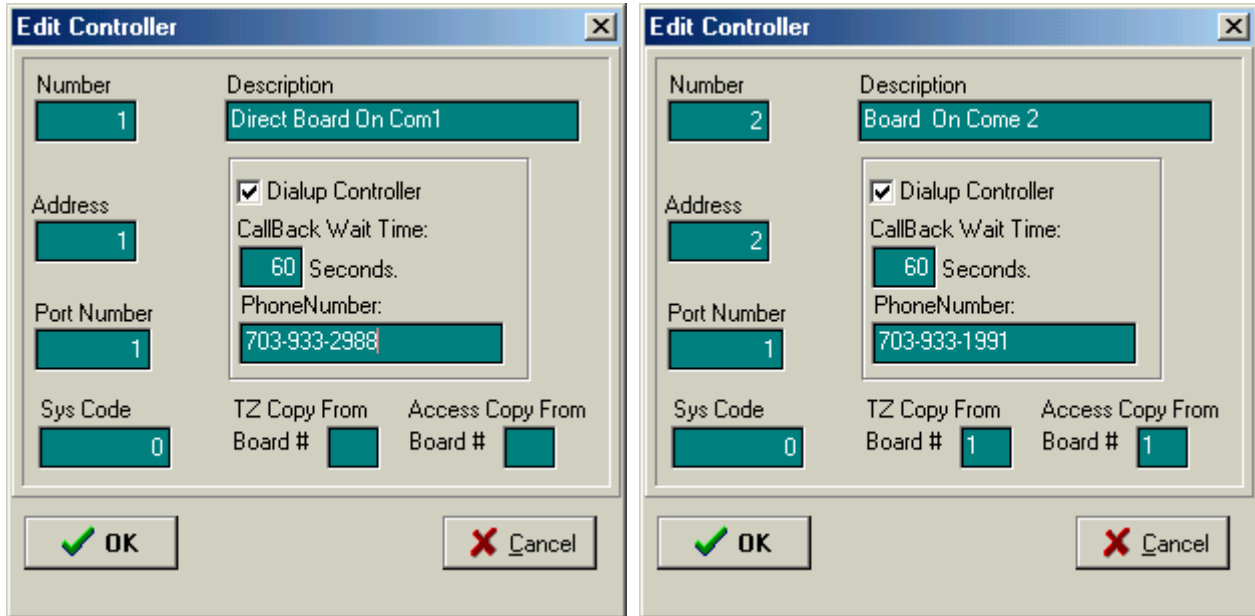

15. If your access levels and time zones are different for doors controlled by Controller 2 then you will need to create the new time zones and new access levels. Follow the directions in **Sections E and G.**
16. To view the Device definition information, using your mouse, double click on the highlighted Device as shown below.

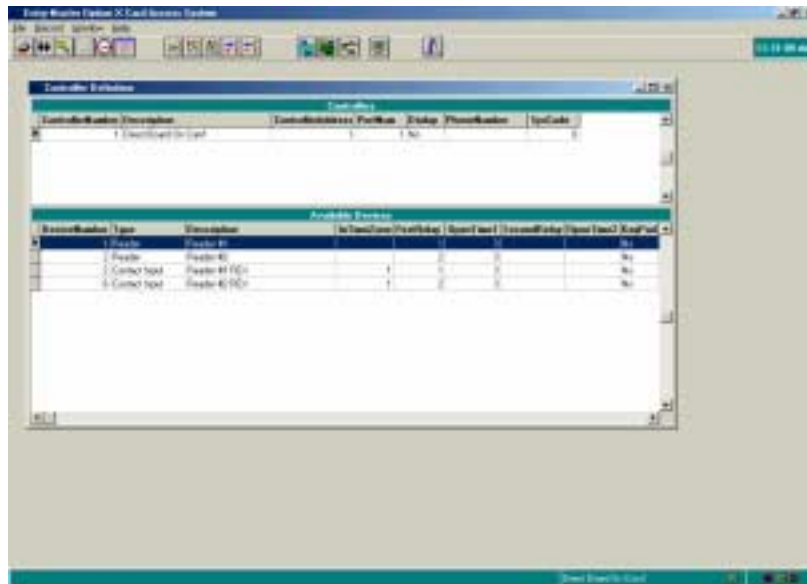

17. The next window pops up displaying the current definitions as shown below.

Device Definition

On Controller:

DeviceType: Reader Reader Number: 1 Description: Reader #1

Open Relay # 1 For 3 Seconds. Normally Open

Open Relay # For Seconds.

In Time Zone: Don't Report During Time Zone

Available Time Zones:

ZoneNumber	Interval	StartTime	EndTime	Mo
1	1	12:00:00 AM	11:59:59 PM	Tue

Shunt Device

Shunt 1: 0 Reader

Shunt 2: 0 Reader

Shunt Time: 30 Seconds

OK Cancel

When Device Type is **Reader**, as shown in the previous window, you can define up to two outputs to activate when a valid card is read. Typically only one output will be used to control the locking mechanism. In this example, when a valid card is presented to **Reader #1**, then **Relay #1** is energized for three (3) seconds. The second output might be used to shunt an external alarm system. **Contact your dealer or EMS for more information.**

18. On your **Option-2** System you have two outputs per reader, a relay and a transistor output. The most commonly used output is the relay this is where you would typically connect your lock. In the Option-X software, **Relays 1 & 2** are referred to as *Relays 1 & 2*, respectively. **Transistor 1** is referred to as *Relay 3* and **Transistor 2** is referred to as *Relay 4*.
19. It may be desirable to have a door remain **unlocked** during a particular time schedule (such as a Front Door remaining unlocked during regular business hours). To define this in the software, select the down arrow next to **Device Type** and select the second item from the pull down menu, **Relay** as shown in the window below.

Device Definition

On Controller:

DeviceType: Relay Relay Number: 1 Description: Door #1 - Unlock 7:30am-5:30pm

Open Relay # [] For [] Seconds.

Open Relay # [] For [] Seconds.

In Time Zone: 2 Don't Report During Time Zone

Available Time Zones:

ZoneNumber	Interval	StartTime	EndTime	Mo
2	1	7:30:00 AM	5:30:00 PM	True

Shunt Device

Shunt 1: 0 Reader

Shunt 2: 0 Reader

A. P. Mode

In Out Neutral

Shunt Time: 0 Seconds.

OK Cancel

20. *Relay 1* is usually associated with **Reader 1**, and *Relay 2* is usually associated with **Reader 2**. There are also *Transistor 1* and *Transistor 2* outputs. As indicated previously, these outputs are addressed in the software as relays 3 and 4. Unless you are familiar with using transistor outputs we recommend you use the relay outputs. If you find it necessary to use the transistor outputs **contact your dealer or EMS for assistance**.
21. The example above unlocks the Front Door between the hours of 7:30am and 5:30pm, Monday through Friday. This is because the user entered a '2' into the **In Time Zone** field.
22. The diagram below illustrates the circuit board in your enclosure. The blue screw connectors for Reader 1, Transistor 1 and Relay 1 are located along the left hand side of board. The blue screw connectors for Reader 2, Transistor 2, and Relay 2 are located on the right hand side of the board.

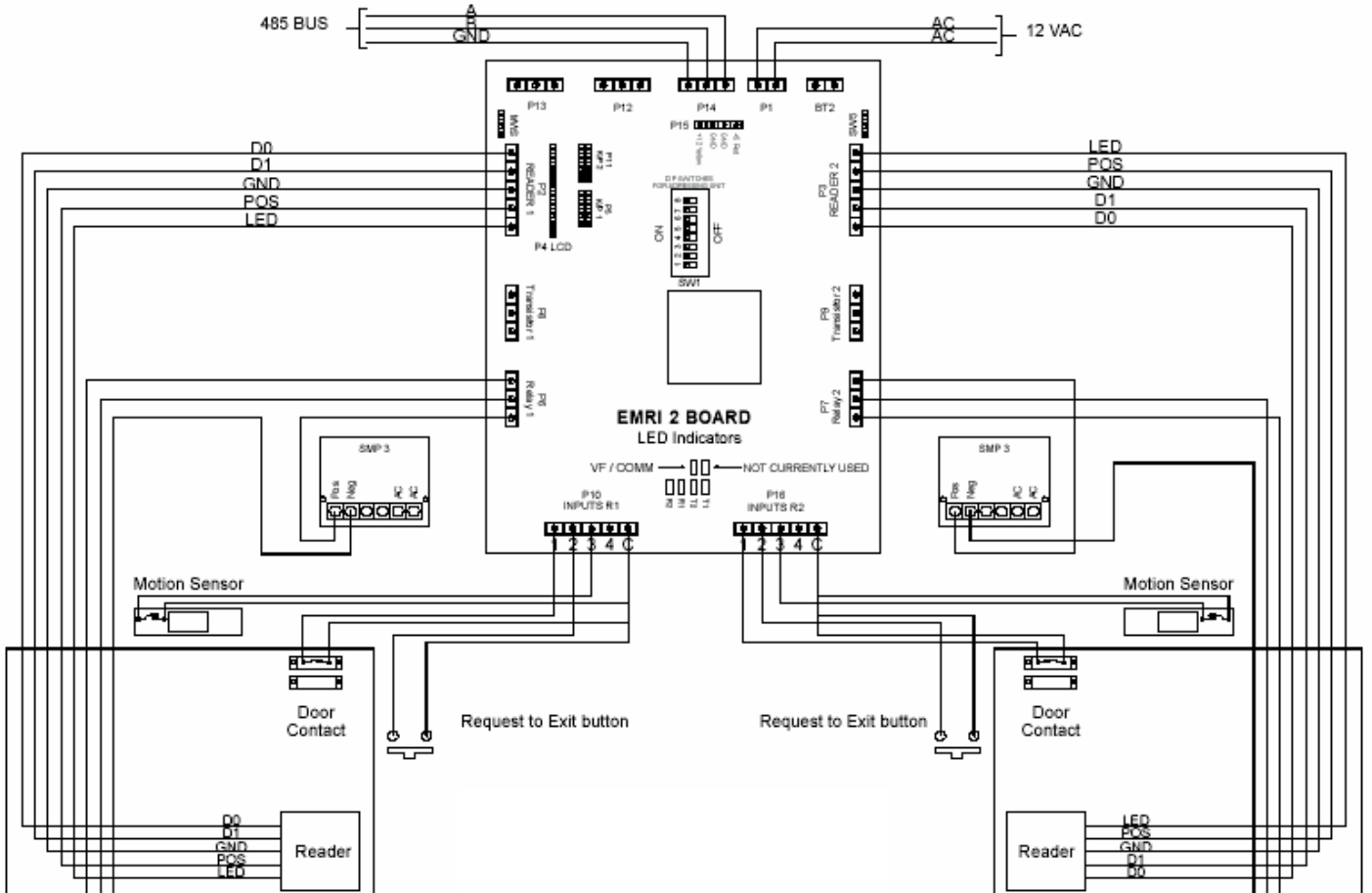

23. The third device type is **Contact Input** as shown in the window below:

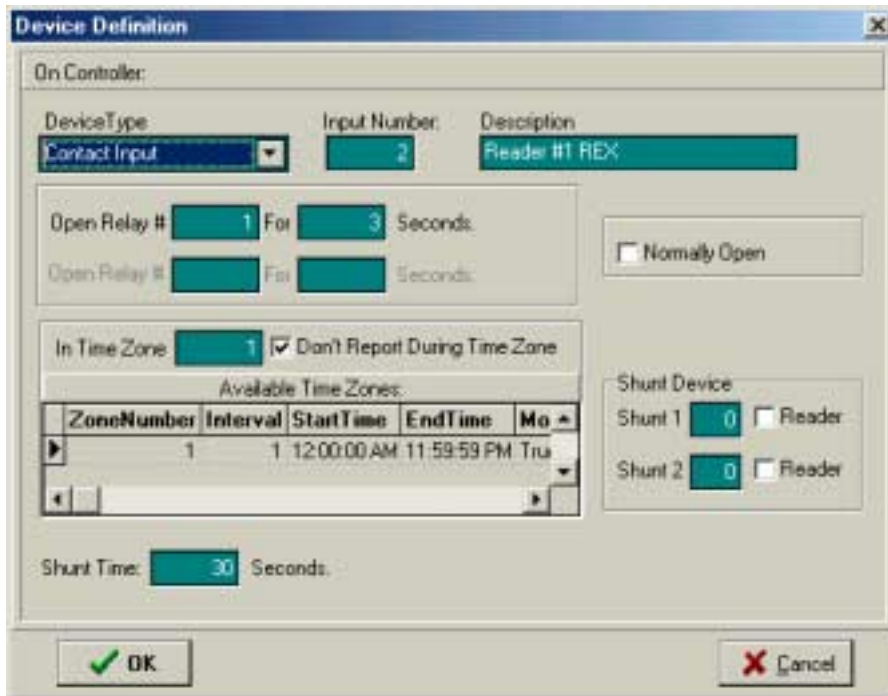

Contact Input would be selected when a **Request to Exit Button** (Ability to Unlock the Door with the Push of a button) is required. For example, the Secretary pushes a button to unlock the door to allow a visitor in. **Contact Input** would also be selected if a **door contact or alarm input** is required, that is, providing an output to an external alarm system or to provide warning when a door has been propped open.

24. Once you have wired your devices to the circuit board in the enclosure and you have defined your devices in the software as described above Test your output. If you find that the door is reporting backwards, the system says the door is closed when it is really open, look at how the the **Normally Open Box** is defined in the software as shown below:

Device Definition

On Controller:

DeviceType: Contact Input Input Number: 2 Description: Reader #1 REX

Open Relay # 1 For 3 Seconds.

Open Relay # For Seconds.

In Time Zone 1 Don't Report During Time Zone

Available Time Zones:

ZoneNumber	Interval	StartTime	EndTime	Mo
1	1	12:00:00 AM	11:59:59 PM	True

Shunt Device

Shunt 1 0 Reader

Shunt 2 0 Reader

A. P. Mode

In Out Neutral

Shunt Time: 30 Seconds.

OK Cancel

If the door is reporting correctly, leave it as is. If the door is not Reporting correctly change the status of the **Normally Open Box**, that is check it if it is not checked, uncheck it if it is checked.

25. You must put a time zone for when the door contact is active. Typically it would be 24 hours. If it is designed to be a request to exit button, as described in **Section 21** above, check the **Don't Report During Time Zone button** as shown in the window above, because you don't want a record every time a button is pressed to let customers in.

24. To **schedule a door to be unlocked** during normal business hours:
- From the **File** menu select **Reader Controllers** or left-click on the fourth icon from the left, **Controllers**. The Controller Definitions window will open.
 - Click on **Device Number 1**, Reader # 1 to highlight it. Then click on the **Add Record Button (See Page 14)**. The following screen will appear:

Device Definition

On Controller:

DeviceType: **Reader** Reader Number: [] Description: []

Open Relay # [] For [] Seconds. Normally Open

Open Relay # [] For [] Seconds.

In Time Zone [] Don't Report During Time Zone

Available Time Zones:

ZoneNumber	Interval	StartTime	EndTime	Mo
1	1	12:00:00 AM	11:59:59 PM	Tru

Shunt Device

Shunt 1 [0] Reader

Shunt 2 [0] Reader

A. P. Mode

In Out Neutral

Shunt Time: [0] Seconds.

- Click on the down arrow next to the **Device Type** window and select the second item in the pull down list, **Relay**.
- In the **Relay Number** window type the relay number you wish to control (in this example, '1'). In the **Description Window**, type a description that indicates which Door will be opened.
- Then click the arrow on the right side of the **Available Time Zones** window to identify the time zone during which the door should be unlocked. Type this number in the **Time Zone** box. An example window might look like the following:

Device Definition

On Controller:

DeviceType: Relay Relay Number: 1 Description: Door #1 - Unlock 7:30am-5:30pm

Open Relay # [] For [] Seconds.

Open Relay # [] For [] Seconds.

In Time Zone: 2 Don't Report During Time Zone

Available Time Zones:

ZoneNumber	Interval	StartTime	EndTime	Mo
2	1	7:30:00 AM	5:30:00 PM	True

Shunt Time: 0 Seconds.

Normally Open

Shunt Device

Shunt 1: 0 Reader

Shunt 2: 0 Reader

A. P. Mode

In Out Neutral

OK Cancel

f. Click on the **OK** button to complete the instructions.

I. Load Board

1. The purpose of the **Load Board** function is to upload the information entered into the software into the Option-2 Panel. Information entered in the software provides the logic used by the Option-2 Panel to determine whether an employee has permission to enter through a specified door.
2. Using your mouse, place the cursor on the **Load Board Icon** and left-click on the icon. The following window displays:

IMPORTANT NOTE: If the *Load Board* function ever locks up or otherwise does not finish, try the "Load" again. If after two or three tries, it still will not finish, exit the Option-X software, re-enter, log back in, and try again. If this does not solve the problem, re-boot your Windows computer, log back in and try again. If the problem persists, call technical support.

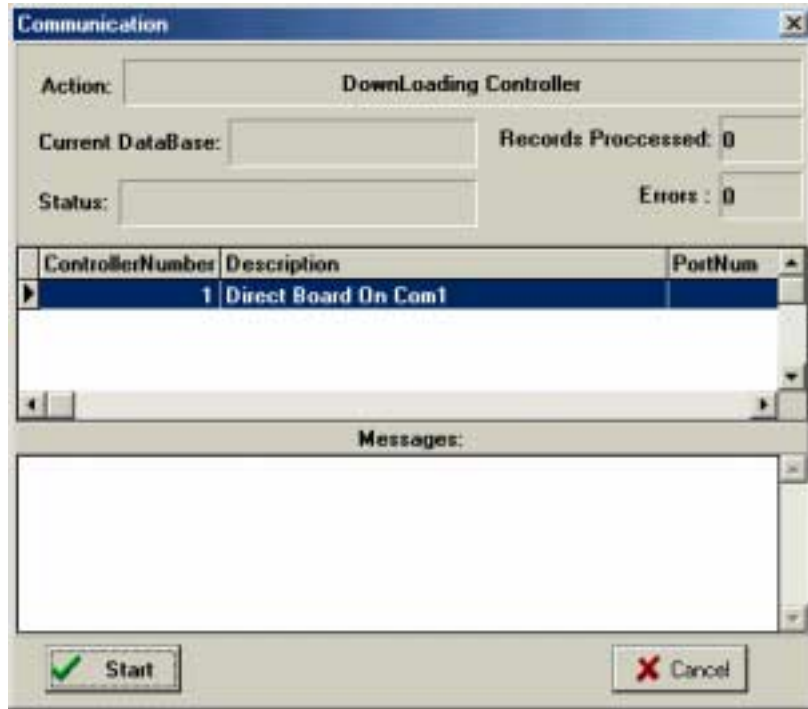

- Using your mouse, left-click on the **Start Button**, the software data will transfer to the panel as shown in the next display:

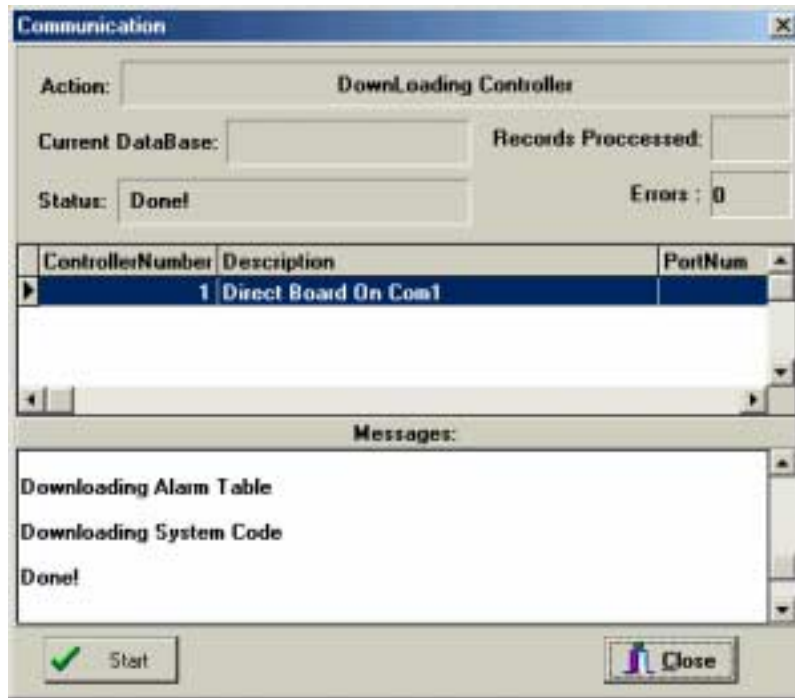

- The last message to display will be **Done!** Click on the **Close Button** as shown in the window above.

J. Device Control

1. The **Device Control** function allows you to manually control (unlock) a door. This is the icon located to the right of the **Set Date and Time Icon (see Page 11)**. When the **Device Control Icon** is depressed the following window displays:

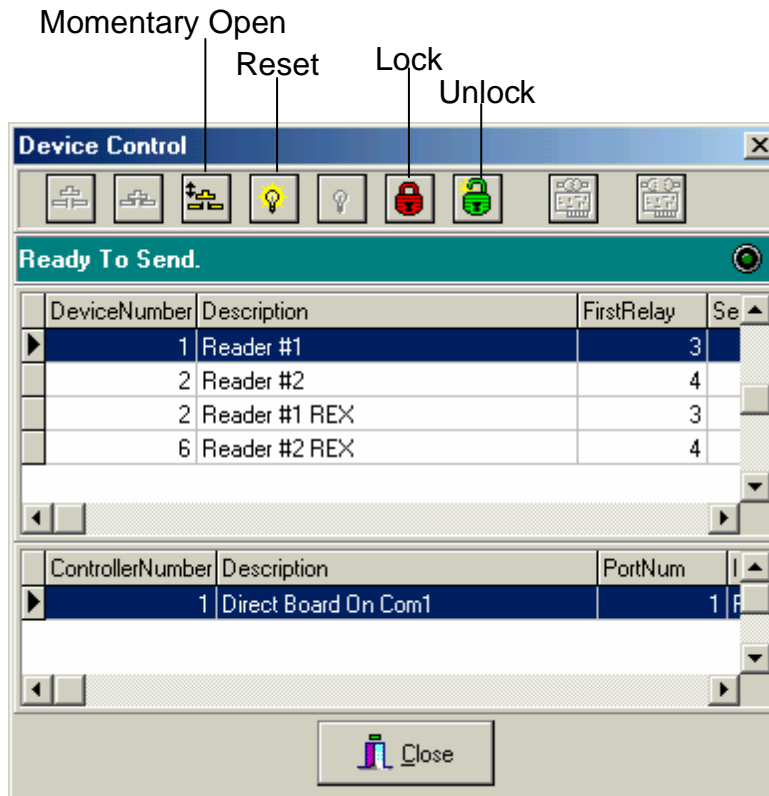

2. In the window above, *Reader #1* is highlighted. If the **Momentary Open Button** is selected, the door associated with this reader will unlock for a few seconds and will then relock. If the **Reset Button** is selected, the original settings for the door associated with this reader are reinstated (**Note: Reset does not function at this time**). If the **Unlock Button** is selected the door associated with this reader will unlock and will stay unlocked until the **Lock Button** is selected.
3. To exit the **Device Control** window, left-click on the **Close Button**.

K. Open Activity Monitor

1. The **Open Activity Monitor** function opens a window that reports access control transactions in real-time as they occur. Left-click on the **Open Activity Monitor** to display the following window:

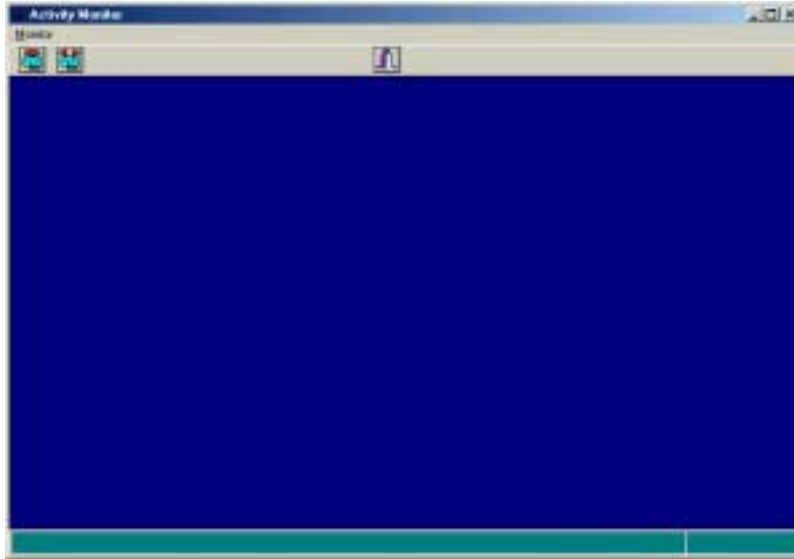

2. As employees use their access control card to enter doors the event is displayed on the screen as shown in the window displayed below:

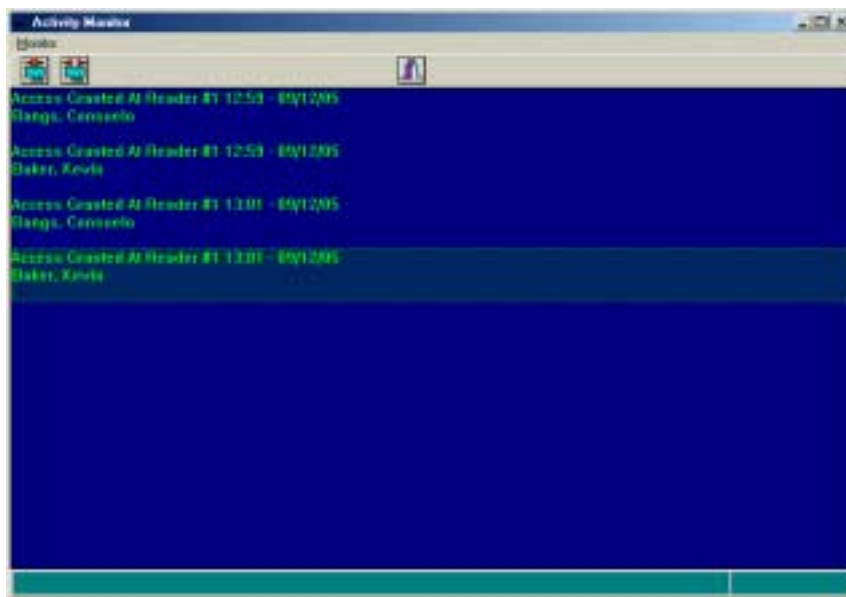

3. To close the **Activity Monitor** screen, left-click on the 'x' in the upper right hand corner of the **Activity Monitor** window, or click on the **Close Window** icon, located in the center of the Activity Monitor window.

L. Printing Reports

1. The Option-X Access Control System Software has the capability to generate two kinds of reports. To produce reports, left-click on the **File Menu** at the top of the screen, select **Print Reports** and select the type of report you wish to view and/or print: **Transaction History** or **Personnel**.
2. When **Transaction History** is selected from the pull down menu the following window displays:

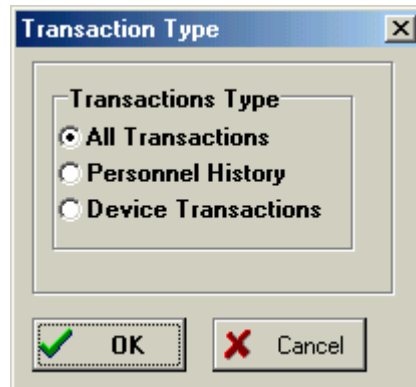

All Transactions reports a date range, the date of each individual transaction, the transaction (access granted or denied), the door (reader/device) on which the transaction took place, the number of the card presented, the first and last name associated with the card number.

- a. To generate this report, left-click on the **OK** button. The following window displays:

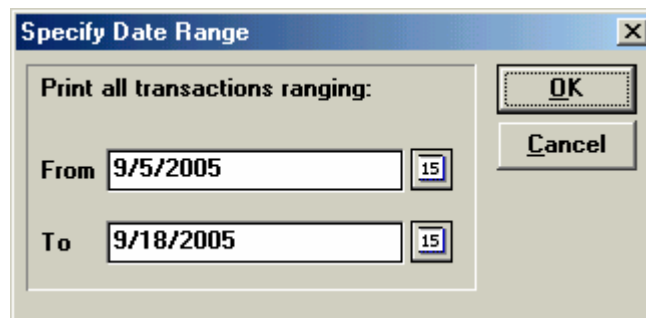

- b. The date range can be changed by clicking on the calendar square at the end of each window or by left-clicking inside the **From** and **To** window and manually typing the date range for which you wish to view data. Click on the **OK** button to generate the report.

- c. The report will then print to the screen as shown in the display below.

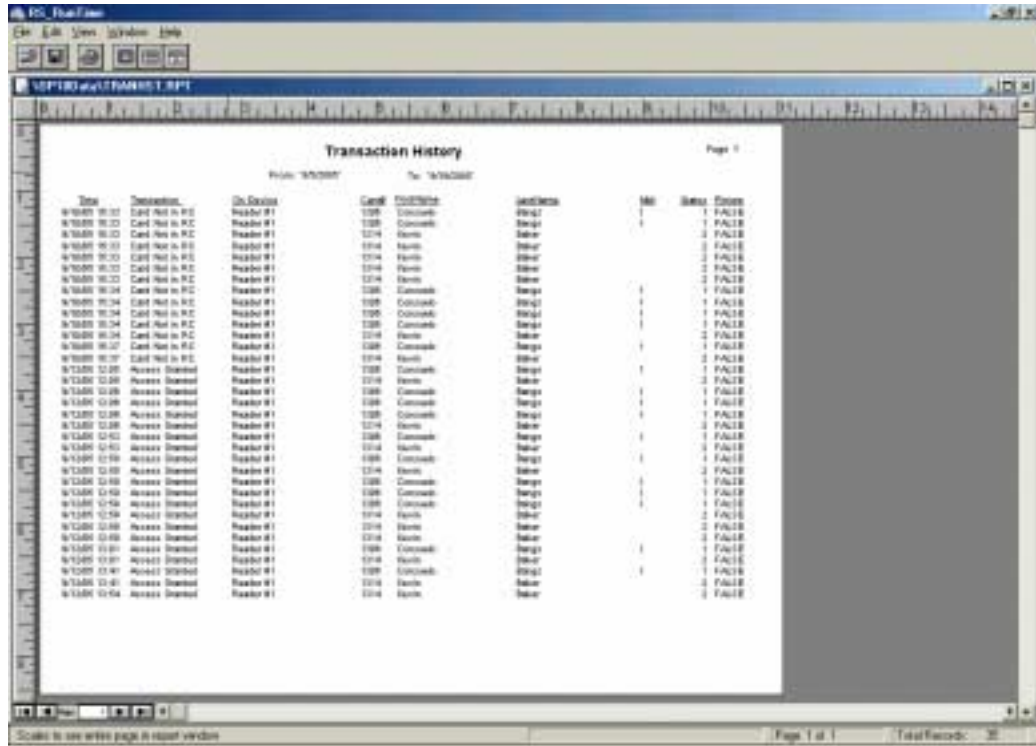

- d. Reports generated may be: saved electronically to a file, by left-clicking on the icon of a floppy disk or printed by left-clicking on the icon of a printer.
- e. To close the report and open a saved report, left-click on the X in the right hand corner of the report, next, left-click on the icon of a file, the following screen will display:

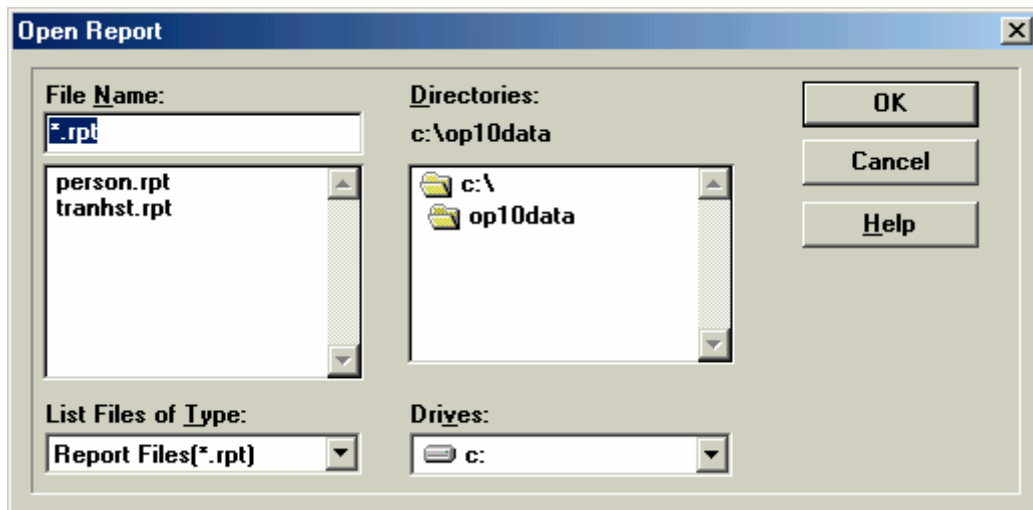

- f. Selecting **person.rpt** and left-clicking on the **OK** button will generate the most recent Personnel report (described below in **Section L. Printing Reports number 3**).
 - g. Selecting **tranhst.rpt** and left-clicking on the **OK** button will generate the most recent **Transaction History Report** described above.
3. **Personnel History** reports the card number assigned to each employee, the employee's first name, last name, and middle initial and whether the employee has log on rights to the *Option-X Access Control System* (**Supervisor True or False**).

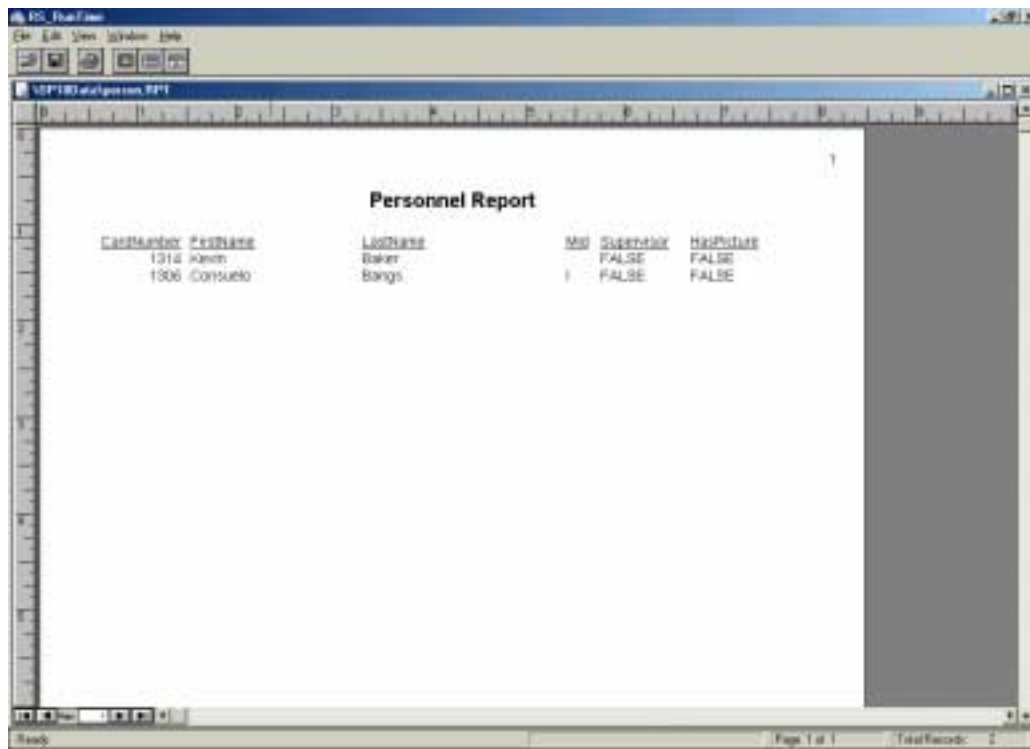

CardNumber	First Name	Last Name	MI	Supervisor	HasPrint
1314	Kevin	Baker		FALSE	FALSE
1306	Consuelo	Bangs		FALSE	FALSE

- a. Reports generated may be: saved electronically to a file, by left-clicking on the icon of a floppy disk or printed by left-clicking on the icon of a printer.
- b. To close the report and open a saved report, left-click on the X in the right hand corner of the report, next, left-click on the icon of a file and choose the report you wish to run.

Appendix A. Using the iButton Tokens

A. What is an iButton Token?

An **iButton**[®] token is a computer chip enclosed in a 16mm thick stainless steel can. Because of this unique and durable container, up-to-date information can travel with a person or object anywhere they go. The steel iButton can be mounted virtually anywhere because it is rugged enough to withstand harsh environments, indoors or outdoors. It is small and portable enough to attach to a key fob, ring, watch, or other personal items, and be used daily for applications such as access control to buildings and computers, as well as asset management.



An iButton token prior to assembly

iButton is a registered trademark of Dallas Semiconductor Corporation.

B. What Part of the iButton Identification Number does Option-4 Use?

The Option-4 system uses the **last five letters or numbers** of the iButton token. Refer to **Figure 1** below:



Figure 1. iButton tokens; the one on the right would be entered in as **12AEB** in the Option-X software.

So, if we were entering the iButton token, shown at the above right, into the Option-X software, our screen might look something like this (**Figure 2** on the following page):

The screenshot shows a window titled "Edit Card Holder" with the following fields and values:

- Last Name : Smith
- First Name : John
- Initial : Q
- Card Number : 76523
- iButton : 12AEB
- Access Level : 1
- AntiPassback : In, Out, Neutral/Forgive, Master

Buttons at the bottom right: OK (with a green checkmark icon) and Cancel (with a red X icon).

Figure 2. Adding an iButton token into the Option-X Software Cardholder Screen

Note that the iButton number is *automatically* converted into a "regular" card number. If you had typed the number **76523** into the **Card Number** field, it would have converted it into **12AEB** in the **iButton** field.

The two numbers are essentially the same; the only difference is that while the **Card Number** field is in decimal (a numbering system with which we are all familiar), the **iButton** field is that same number represented in *Hexadecimal* or *Base 16* numbering system format.

It is not necessary for you to understand the hexadecimal numbering system or how it works; you only need to remember to enter your **iButton** token number in the **iButton** field.

The only reason that both **Card Number** and **iButton** fields are present is to enable the Option-X software to work with either the Option-2 or Option-4 access control systems.

This Page is Intentionally Left Blank.