

# ***Entry-Master<sup>®</sup>*** ***Option-2***

## ***Installation Guide***



**A Publication Provided By**



**3106 Lord Baltimore Drive, Suite 100  
Baltimore, Maryland 21244  
Phone (410) 594-1805  
Fax (410) 594-1808**

## Entry-Master® Option-2 Access Control System Hardware Installation Guide

### A. Understanding the Option-2 Circuit Board

1. Your *Option-2 Access Control System* included a lockable, assembled enclosure. Open the enclosure and you will see the following:



2. The picture above displays the inside of your enclosure which includes:
  - i. An electrical diagram of the Option-2 circuit board posted on the inside of the enclosure door.
  - ii. The Option-2 circuit board secured to the inside of the enclosure.
  - iii. A set of two (2) enclosure keys.
  - iv. A 9-pin RS232 communication cable connected to a blue screw connector at the top of the Option-2 circuit board
  - v. An *Option-X Software* CD, including copies of the user manuals and other useful information.
  - vi. Blue *Phoenix-type* connectors labeled and placed around the outer edges of the Option-2 circuit board. All connectors are designed to be removable for easy connection.

3. The Option-2 board is capable of controlling two (2) doors using proximity or wiegand-type card readers.
4. All inputs and outputs are independently programmable through the *Option-X Access Control Software*.
5. Follow the 9-pin RS232 communication cable back to the blue connector to which it is connected on the Option-2 board. Locate the label **P12 RS232** directly under the connector.
6. Move to the right to the next blue connector. This is the **P14 RS485** connector. It is not presently implemented on the Option-2 System. To the right of it, you will find the **P1 Power** connector.
7. Refer to **Figure 1** below for connecting devices to the Option-2 circuit board:

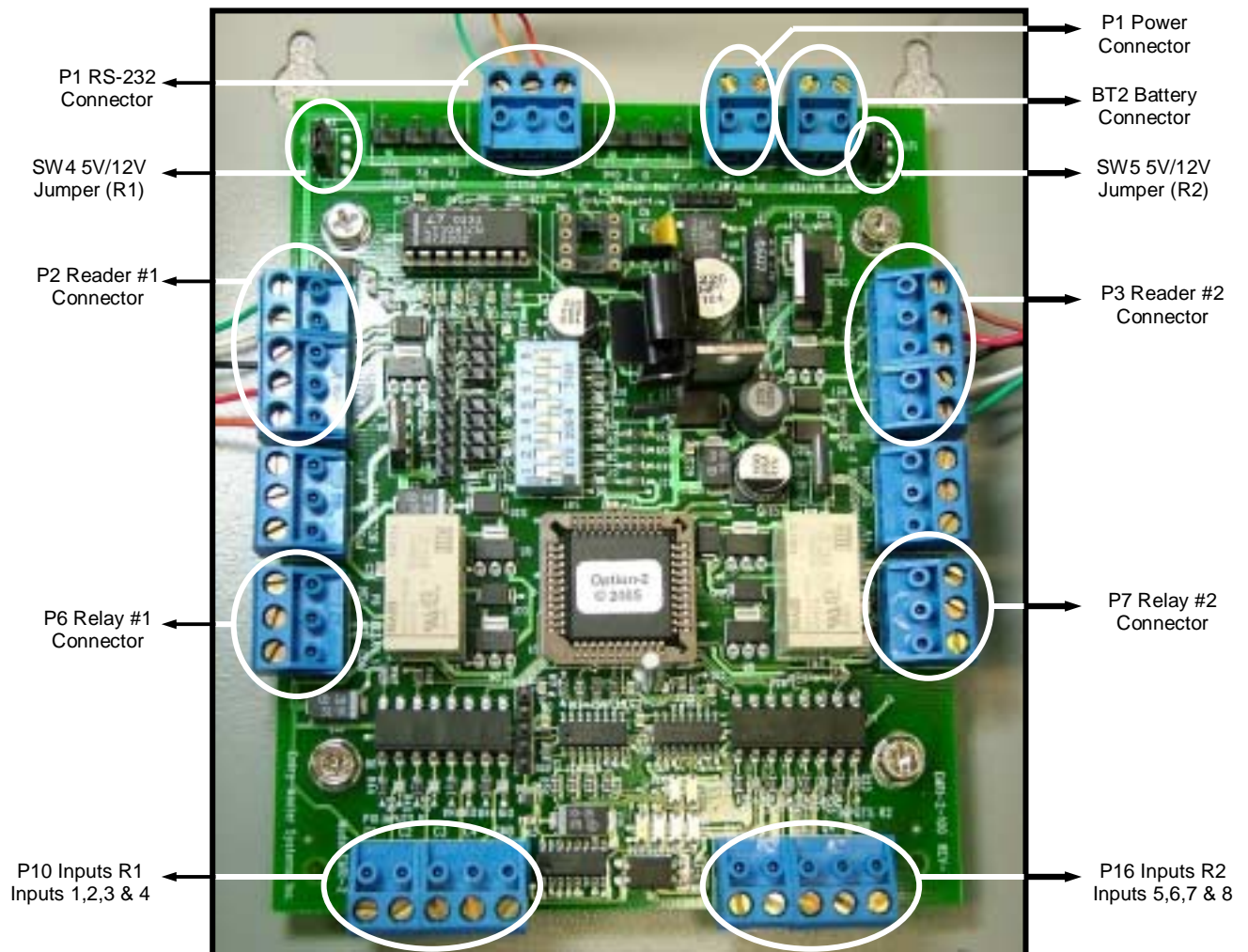

Figure 1. Option-2 Circuit Board

## B. Power Instructions

1. The Option-2 board can be powered by AC or DC, from 12V up to 24V input. However, the Option-2 board only provides a maximum of 12V DC on any of its outputs, or for card reader power.
2. It is **strongly recommended** you use a 12-volt AC power transformer with at least 20-volt-amps (VA) of output power. If the VA rating is higher than 20 the Option-2 circuit board will only draw the power it needs.
3. You will notice above the **P1 Power** label on the Option-2 circuit board there is not (+) or (-) but a (~) symbol under each pole of the blue connector. Because the Option-2 circuit board can use either AC or DC power, polarity is not an issue. Either pole can handle (+) or (-) current. Note that this is not the case with the battery back up located to the right and labeled **BT2 Battery**. **Polarity is important when connecting a battery back up.**
4. The Option-2 board will retain its memory (i.e. cardholders, access groups, time zones, etc.) in the event power is lost. However, there is no real-time clock on the Option-2 board, so a power loss resets the board's date and time to a default date. For this reason, **it is highly recommended that a battery backup be used!** For battery back up you must use a 12-volt gel cell battery. The (+) terminal of the battery must be connected to the blue screw on the connector labeled (+) and the (-) terminal of the battery must be connected to the blue screw on the connector labeled (-).
5. Listed below are the Electrical Specifications for the Option-2 circuit board:

ELECTRICAL SPECIFICATIONS	
Supply power:	12-24V AC or DC @ 500mA Max.  Note: this includes reader power but does not include lock or relay power.
Relay Contacts:	250VAC @ 5A Max.
Transistor:	24VDC Max. collector to ground. 1A sink current without heat sink installed. 2A sink current with heat sink installed.
Contact inputs:	Source 12VDC @ 1mA.
Backup Battery Recommendation:	12V 7.2AH Sealed lead-acid (Gel-Cell) battery.  Note: This should run the EMRI-2 board with two readers and power fail-secure locks with occasional use for about 4 hours.

6. **Please Note:** When using 16 to 24 volts AC to power the Option-2 circuit board, the heat sink on the 12V regulator will get quite hot. *This is normal and is not a cause for concern.*
7. Plug the transformer into a standard 110V wall outlet. You will see a blinking light near bottom of the Option-2 circuit board. This indicates the board is receiving power and that the microcontroller is functioning.

### C. Connecting the Readers

1. The Option-2 circuit board is capable of supporting either 5V or 12V power requirements for card readers being used. **If the card readers being used require 24V power to operate, then an external power supply must be used to provide power to the card readers.**
2. To the right of the **BT2 Battery** blue connector you will see three poles labeled **SW5**. At the opposite corner of the board you will see three poles labeled **SW4**. **SW4** enables selection of the power required for *Reader 1* and **SW5** enables selection of the power required for *Reader 2* (see **Figure 1** on page 2).
3. The Option-2 circuit board is usually delivered set to provide 5V power to each card reader. If your readers require 12V power then you will need to gently pull up on the small black jumper and move it over one pole so that it is connecting the center and 12V poles.
4. The next step is to verify the Dip Switch Settings of the Option-2 circuit board. The Option-2 circuit board arrives pre-configured and the switches should not need to be changed. The chart below defines the Dip Switch settings:

#### SW1 - DIP Switch settings

1&2	Should <u>always</u> be in the OFF position on an Option-2 System
3	P8 Transistor 1 (Relay 3 in Option-X software) Output Status On = Normally Open Mode - Off = Normally Closed Mode (Energized)
4	P9 Transistor 2 (Relay 4 in Option-X software) Output Status On = Normally Open Mode - Off = Normally Closed Mode (Energized)
5	On = Retains Memory - Off = Clears Memory upon Power Up
6,7,8	On an Option-2 System, these should all be in the ON position

5. The default settings for the DIP switches are listed below:
  - Switches **1 & 2** should always be in the **OFF** position!
  - Switches **3 & 4** both come from the factory in the **ON** position
  - Dip Switch **5** comes from the factory in the **OFF** position
  - Switches **6, 7 & 8** all come from the factory in the **ON** position
  
6. The Option-2 board supports wiegand-type readers, which include most proximity or other RF-type devices, as well as many bar code and mag-stripe readers. The wiring scheme is described below:

<u>Wiegand Signals</u>		<u>Typical Wire Color</u>
<b>D0</b>	Data 0	Green
<b>D1</b>	Data 1	White
<b>G</b>	Ground	Black
<b>+V</b>	Power (+5V or +12V)	Red
<b>L</b>	LED Control	Brown or Orange



Reader 1 Connections



Reader 2 Connections

7. **Please Note** that the pin-outs for the readers are reversed from one another, if they are looked at from top to bottom of the circuit board; that is to say, on **Reader 1** the pin-outs from top to bottom are: **D0, D1, G, +V and L**, but for **Reader 2** the pin-out from top to bottom are: **L, +V, G, D1 and D0**. They are "backwards" on

purpose, so that a reader can be disconnected from **Reader 1** and plugged directly onto the **Reader 2** position, without rewiring the connector.

8. It is **very important** that shielded cable be used for reader wiring. Specifically, 22AWG stranded, shielded 6-conductor cabling is recommended. It is neither necessary nor desirable to have individual shields for each pair of cables; one overall shield will suffice. It is also not recommended to locate a reader more than 250 feet from the Option-2 board.

#### D. Connecting the Inputs

1. The Option-2 circuit board has two (2) connectors for *Inputs*; inputs are used to monitor doors that may have been propped open, opened without a card, or simply as a **Request to Exit**, also known as a **REX** button or switch, which allows a person to unlock a door from somewhere other than at the door (i.e. a receptionist could press a button under the desk to allow entry through the front door).
2. The connectors are labeled **P10 INPUTS R1** and **P16 INPUTS R2** (see the figures below, and also **Figure 1** on **Page 2**):



**P10 INPUTS R1**  
(C1,C2,C3,C4)

Option-X Inputs 1, 2, 3 & 4



**P16 INPUTS R2**  
(C1,C2,C3,C4)

Option-X Inputs 5, 6, 7 & 8

- Note the correlation between how the inputs are depicted on the board, as opposed to how they are addressed in the *Option-X Software*:

Option-X Input Mapping Chart	
<u>Connector Input</u>	<u>Option-X Software Input Number</u>
P10, Input C1	1
P10, Input C2	2
P10, Input C3	3
P10, Input C4	4
P16, Input C1	5
P16, Input C2	6
P16, Input C3	7
P16, Input C4	8

- To connect an input, simply attach one leg of the two wires of the input to the **Gnd** and the other to the appropriate input. Note that the inputs and outputs on the Option-2 board are completely independent, which simply means that any input can serve any purpose. For instance, **Input 7** (Connector P16, Input C3) could be used to energize **Relay 1** and **Relay 1** could, in turn be used to unlock the door that is presently connected to **Reader 2**.

### E. Connecting the Outputs

- The Option-2 circuit board has four (4) connectors for *Outputs*; outputs are used to control the lock status of doors. The outputs can also be used to lock and unlock doors on a scheduled basis (See the *Option-X Software Manual* for more detail on this).
- The **relay outputs** are most commonly used to control door locks. The Option-4 board contains two (2) relay outputs and two (2) **transistor outputs**. It is strongly recommended that you study the connections used with the transistor outputs (in **Appendix A**) if you are not familiar with transistor-type outputs. Note the correlation between how the inputs are depicted on the board, as opposed to how they are addressed in the Option-X software:

Option-X Output Mapping Chart	
<u>Connector Output</u>	<u>Option-X Software Output Number</u>
P6 Relay1	1
P7 Relay2	2
P8 Transistor 1	3
P9 Transistor 2	4

3. The relay output connectors are labeled **P6 RELAY 1** and **P7 RELAY 2** (see the figures below):



**P6 RELAY 1**

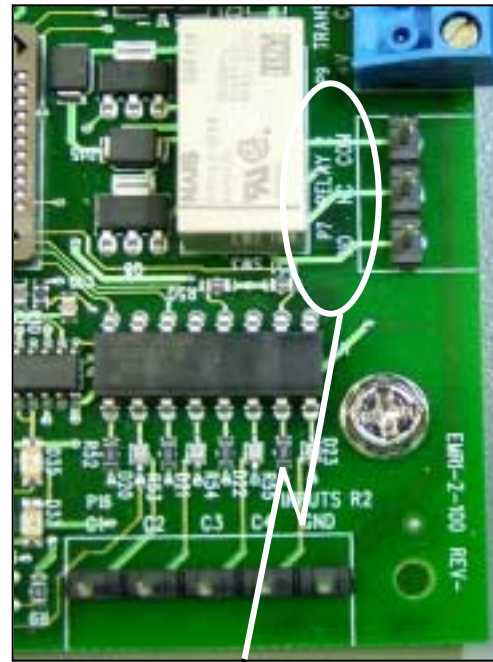

**P7 RELAY 2**

4. The relays each have a **Normally Open (NO)**, a **Normally Closed (NC)**, and a **Common (Com)** connector. The relays are rated to accommodate 250VAC and 5 Amps maximum.
5. **Fail-safe** locking devices will typically use the **NC** and **Com** connectors; **Fail-secure** locking devices will typically use the **NO** and **Com** connectors.
6. It is recommended that *at least* 18AWG stranded, unshielded cable be used. Keep in mind that for every 100 feet of cable used with a locking mechanism, a voltage drop of *approximately 1-Volt* will occur.
7. ***It is also mandatory that a reverse-biased diode be installed across the (+) and (-) wires of any inductive coil!! Failure to heed this warning may result in damage to your Option-2 circuit board.*** See the wiring diagram on **Page 10** for more details. The recommended part number for the diode is **1N4001**.

### F. Recommended Lock Mechanism Wiring Diagrams

Magnetic Locks and Electric Lock Strikes installed as **fail-safe** require power to *stay locked*. When power is lost, Magnetic Locks or fail-safe Electric Lock Strikes will remain unlocked until power is restored.

**Fail-secure** Electric Lock Strikes require power to *unlock*. When power is lost, a **fail-secure** Electric Lock Strike *remains locked*.

The drawing below depicts examples of wiring both fail-safe and fail-secure locking mechanisms to the Option-2 board (EMRI relay refers to the Option-2 board's relay outputs):

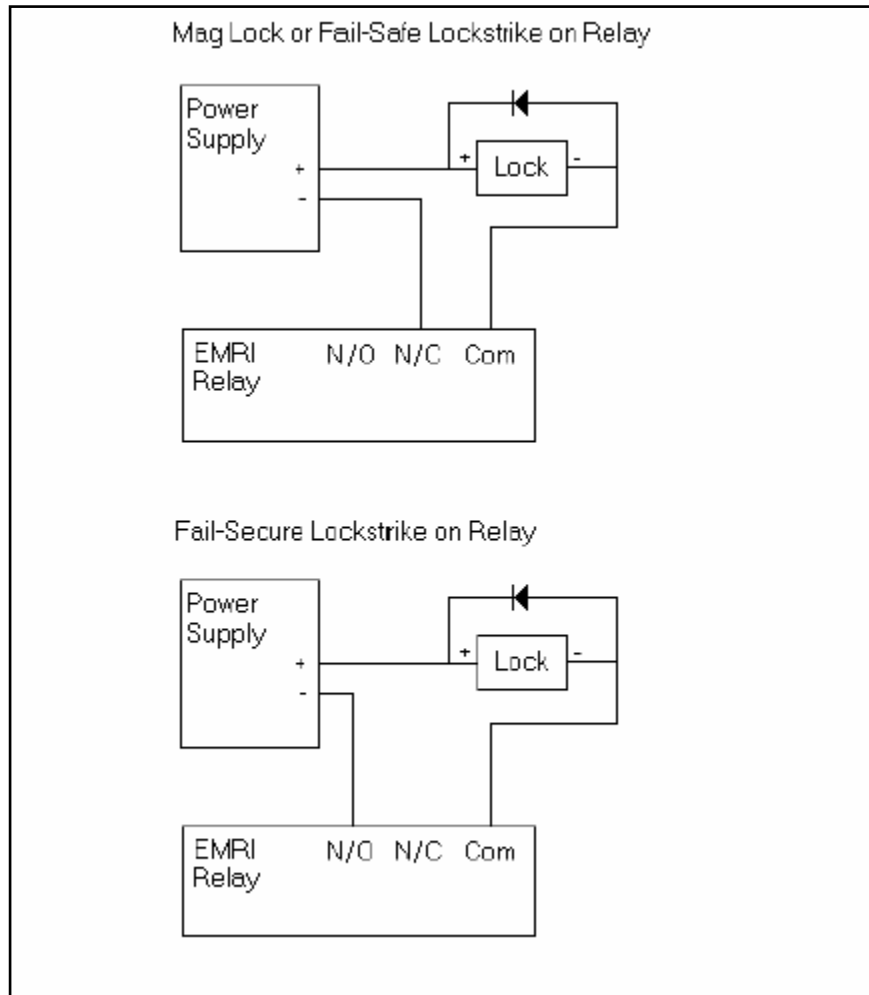

Examples of Wiring Lock Mechanisms up to the Option-2 Relays

**Note:** polarities of the diodes are depicted on the diagram on the following page:

G. Option-2 Board Wiring Diagram

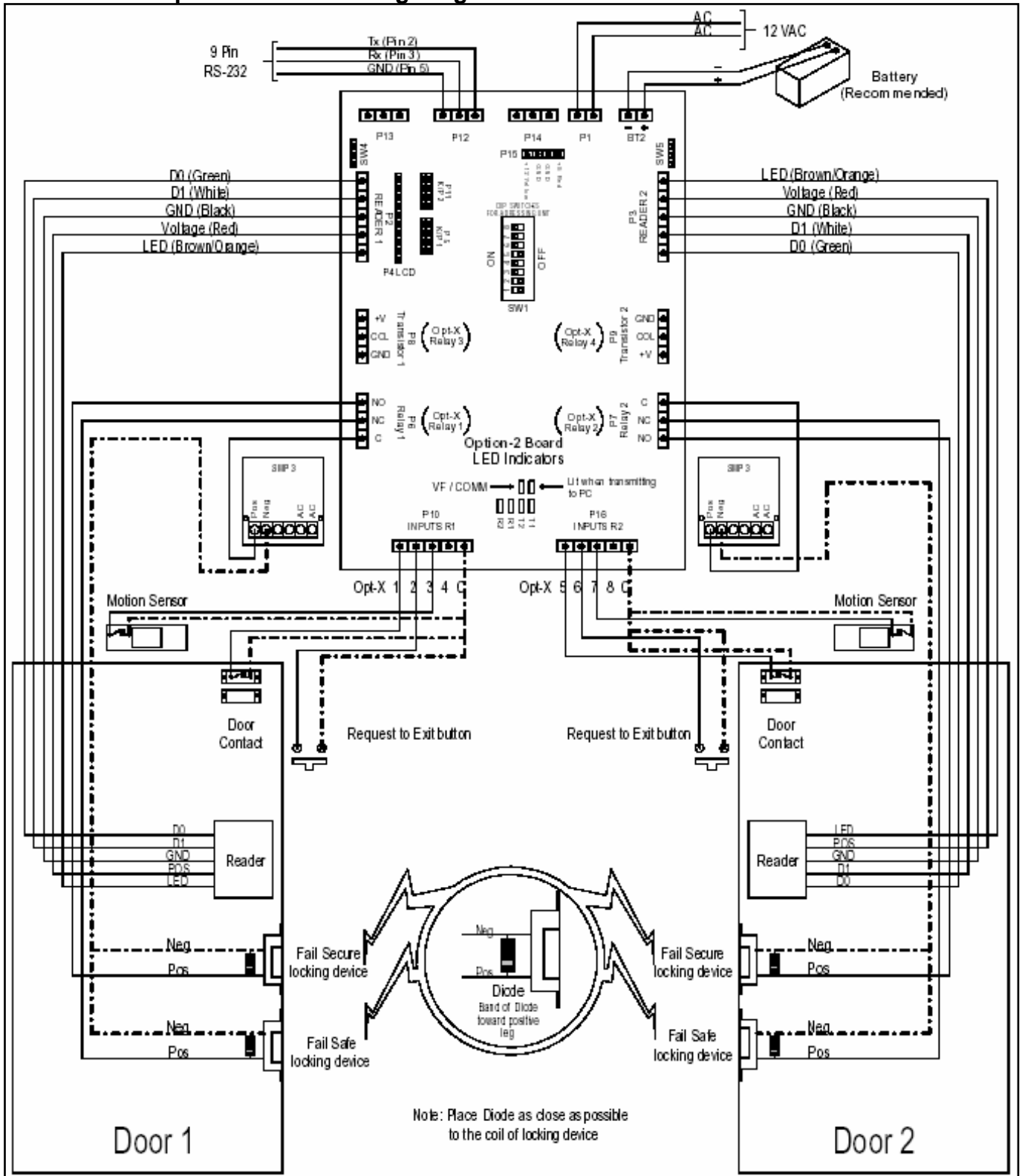

Connecting Readers and Lock Mechanisms to the Option-2 board

**Note:** diodes should be placed as close as possible to the locking mechanism.

## H. Option-2 Circuit Board Restrictions

Here are the recommendations for installing the Option-2 board:

1. Use a separate power supply for locks and sirens (i.e. one power supply for the Option-2 board and a different supply for the peripheral devices).
2. DC inductive loads (magnetic locks, lock strikes, relays, etc.) need to have a reversed-biased diode (**1N4001** recommended) installed as close as possible to the lock or relay coil.
3. Use a **12VAC 20VA** transformer to power a single Option-2 board, and a **12VAC 40VA** to power two (2) Option-2 boards.
4. If an Option-2 board is not powered through a UPS, a battery backup is recommended.
5. Wiring from the readers to the Option-2 board should be done with shielded cable with the drain connected to the ground on the reader side of the cable and not connected on the Option-2 board side of the cable.
6. Use recommended wiring diagram(s) as appropriate (refer to the drawings on **Pages 9 and 10**).
7. The Option-2 board should be well grounded. At least one of the ground leads should be connected to an earth ground.
8. Batteries used for battery backup must be 12V gel-cell lead-acid types. If the board is powered by DC and you wish to use battery backup, DC voltage must be at least 14V. If it's powered by 12-24V AC the board will trickle charge the battery.
9. The transistor outputs can be used for controlling DC locks directly if the activation current is less than 1A. The current can be up to 2A if a heat sink is mounted on the output transistor. Transistor outputs can be used to power a relay to control AC or high power locks, sirens, etc.
10. The internally generated power must be used to power the locks if the board is to operate locks in battery backup mode.
11. All pins labeled **GND** or **G** are connected together. This is important to know to avoid possible damage to the Option-2 board.

## Appendix A. Using the Transistor Outputs

While the use of transistor outputs may seem confusing, it can really be summed up in one simple fact: "... the collector always drops to ground when the transistor is activated."

The "collector" is the middle pin of the 3-pin connector for either transistor output on an Option-2 board. There are three (3) ways of utilizing the transistor output: in the first method, the Option-2 board actually powers the locking mechanism, providing *voltage* to the lock coil. In this case, only the collector (C) and (+V) connectors are utilized (See **Figure 1** below).

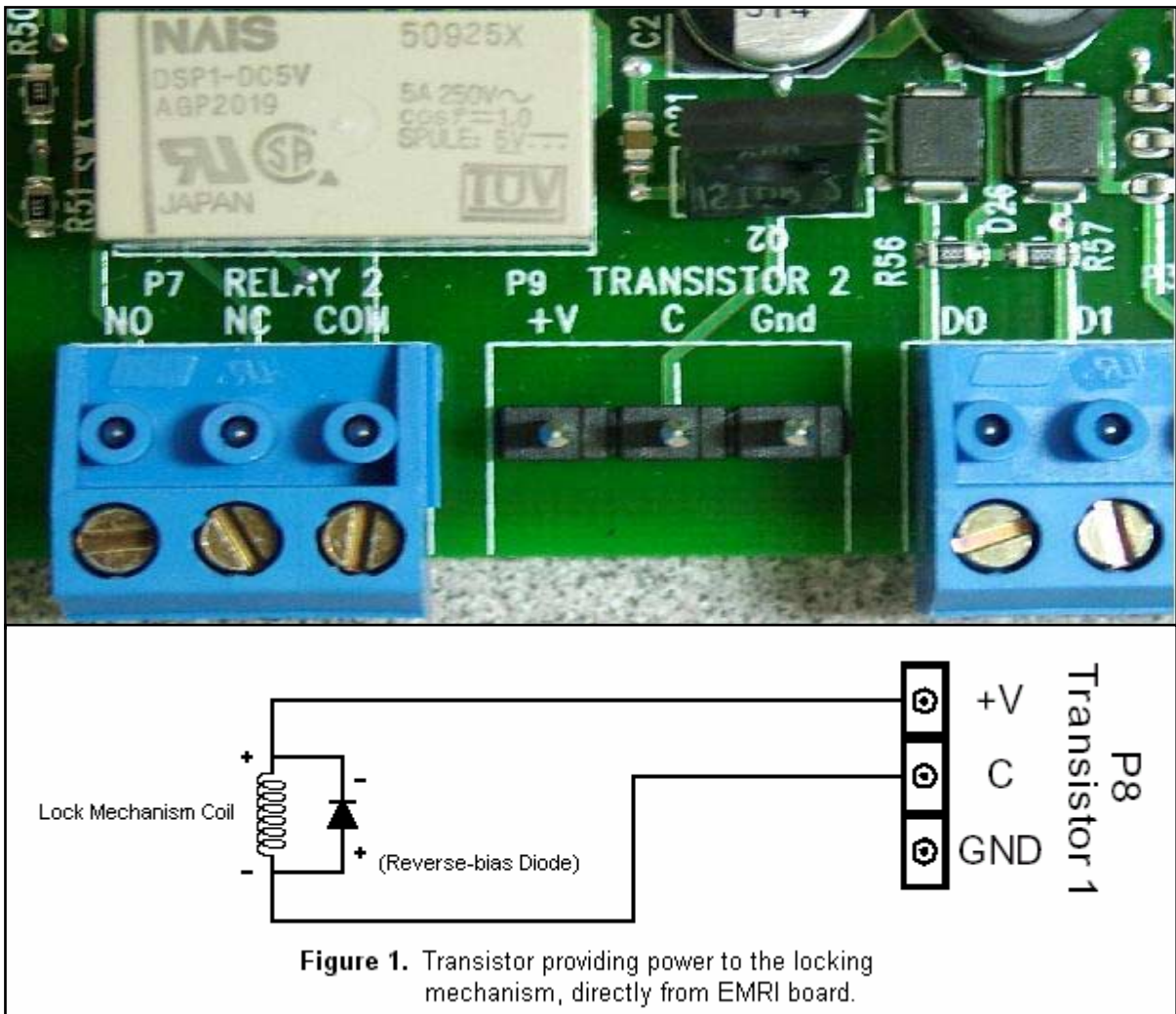

When the transistor output is not active, the collector "hovers" at a voltage close to +V. But when the transistor output switches to "active" the collector essentially "drops" to ground, creating a voltage potential between the collector (C) and (+V) pins, thus providing power to the locking mechanism.

The second method employs the use of an external power supply, and acts very much like a relay output, except that in this case, only the **negative** power lead can be interrupted via the collector (C) output and the ground (Gnd) connector (see **Figure 2** below). In this case, when the transistor output is active, the collector output "drops" to ground, thus allowing the current from the external power source to flow into the locking mechanism.

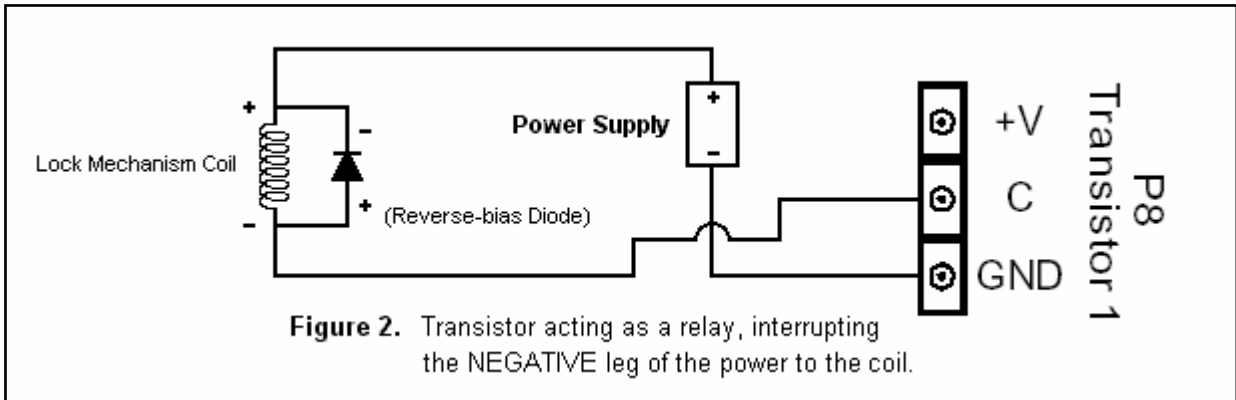

Please note that in **both** cases, a reverse-bias diode is employed across the coil, in order to prevent negative back-feed on the circuit. A diode of type **1N4001** is recommended.

***The installation of diodes is necessary and extremely important!!!***

***Failure to follow these instructions may damage the Option-2 board!!!***

The third method involves the use of an *isolation relay*, powered directly by the transistor. The advantages of this method are: (1) the use of **AC** locking mechanisms (the first two methods can operate only with **DC** power); (2) the voltage and current limitations are dictated by the isolation relay, not the transistor; (3) *either* the positive or negative leg of the lock power may be interrupted by the relay (when using a **transistor** output, only the *negative* leg may be interrupted); and (4) it is a little more straightforward for those who are accustomed to using relays.

In this method, an external power supply is used, but the transistor actually powers the isolation relay (see **Figure 3** below). **Please note** that a reverse-bias diode is installed across **both** the relay coil **and** the locking mechanism coil.

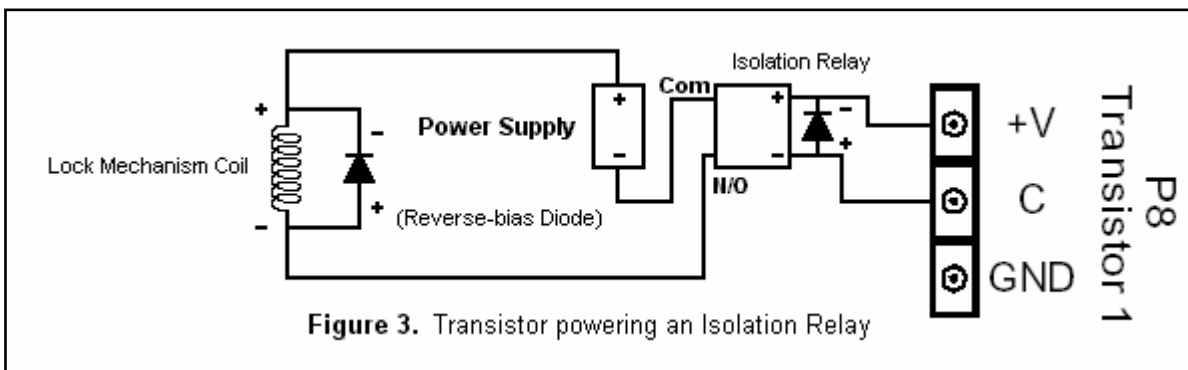

**Things to remember when using Transistor Outputs:**

- ***Always*** use reverse-bias diodes across and as physically close to the locking mechanism coil as possible.
- ***NEVER*** attempt to connect any type of **AC** device directly to the transistor output (for **AC** locks, you must use an isolation relay, as described above).
- Always be sure that the peak voltage being used by the transistor is no greater than **24 VDC** and no greater than **1 ampere** of current.
- When using a transistor output as a "relay" (i.e. as in method #2), you must always break the **negative** side of the external power supply to the locking mechanism coil.
- Fail-safe and fail-secure functionality is accomplished through DIP switches 3 and 4 on the Option-2 board. See the *EMRI-2 Board Installation Guide* for further details.
- Always check polarities, current draw and measure voltages before connecting devices to a transistor output.
- When the transistor is energized or active, the voltage should read about **0.6V** between the collector (**C**) and ground (**Gnd**). If the voltage reads zero volts, then either there is no power through the transistor or you have connected something improperly.

**Obtaining Clear, Up to Date Installation/Engineering Drawings**

The drawings in this manual may not be as clear as you need. To obtain full-page, clear drawings depicting how to connect peripherals to the Option-2 board, use your Internet browser to go to the **Entry-Master Documentation Page**, located at the following URL:

**<http://www.entry-master.com/document.shtml>**

The following documents are located on this web page:

- Option-2 System Cut-Sheet      **<http://www.entry-master.com/Opt-2cut.pdf>**
- Option-2 Wiring Diagram      **<http://www.entry-master.com/Opt2dwg.pdf>**
- Option-2 Installation Guide      **[http://www.entry-master.com/Opt2\\_hw.pdf](http://www.entry-master.com/Opt2_hw.pdf)**
- Option-X Software Manual      **[http://www.entry-master.com/OptX\\_sw.pdf](http://www.entry-master.com/OptX_sw.pdf)**

These documents are also located on the **Installation CD** contained in the Option-2 enclosure, and can be found in the following directory:

**d:\Manuals**, where "**d:**" is the drive letter of your CD-drive.